

# XXI<sup>St</sup> century : The century of Nanoconvergence

*From data storage to power cables*

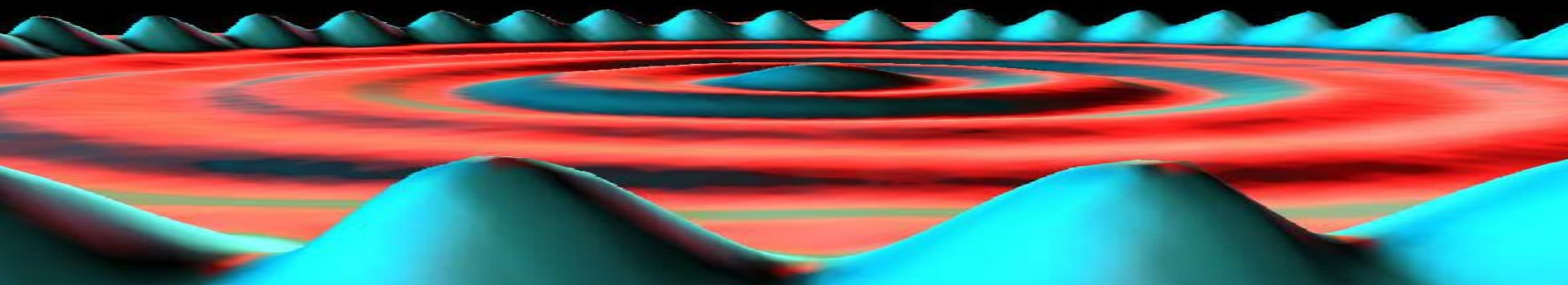

# Nanotechnology is not new !

*Lycurgus' cup, Roman Empire IV<sup>E</sup> Century, British Museum*



Transmitted light = red ; reflected light = green  
(40 nm particles in the glass)

# What is nanotechnology ?

Convergence between technology, physics, chemistry and biology

Exploit the specific properties of the world at atomic scale (mesoscopic and quantum effects)

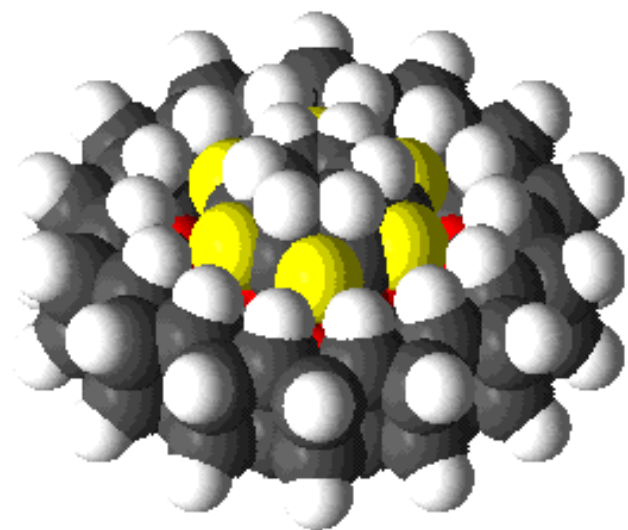

*If I were asked for an area of science and engineering that will most likely produce the breakthroughs of tomorrow, I would point to nanoscale science and engineering*

Neal Lane, Former Assistant to the US President for Science and Technology

# Melting point depends on the size !

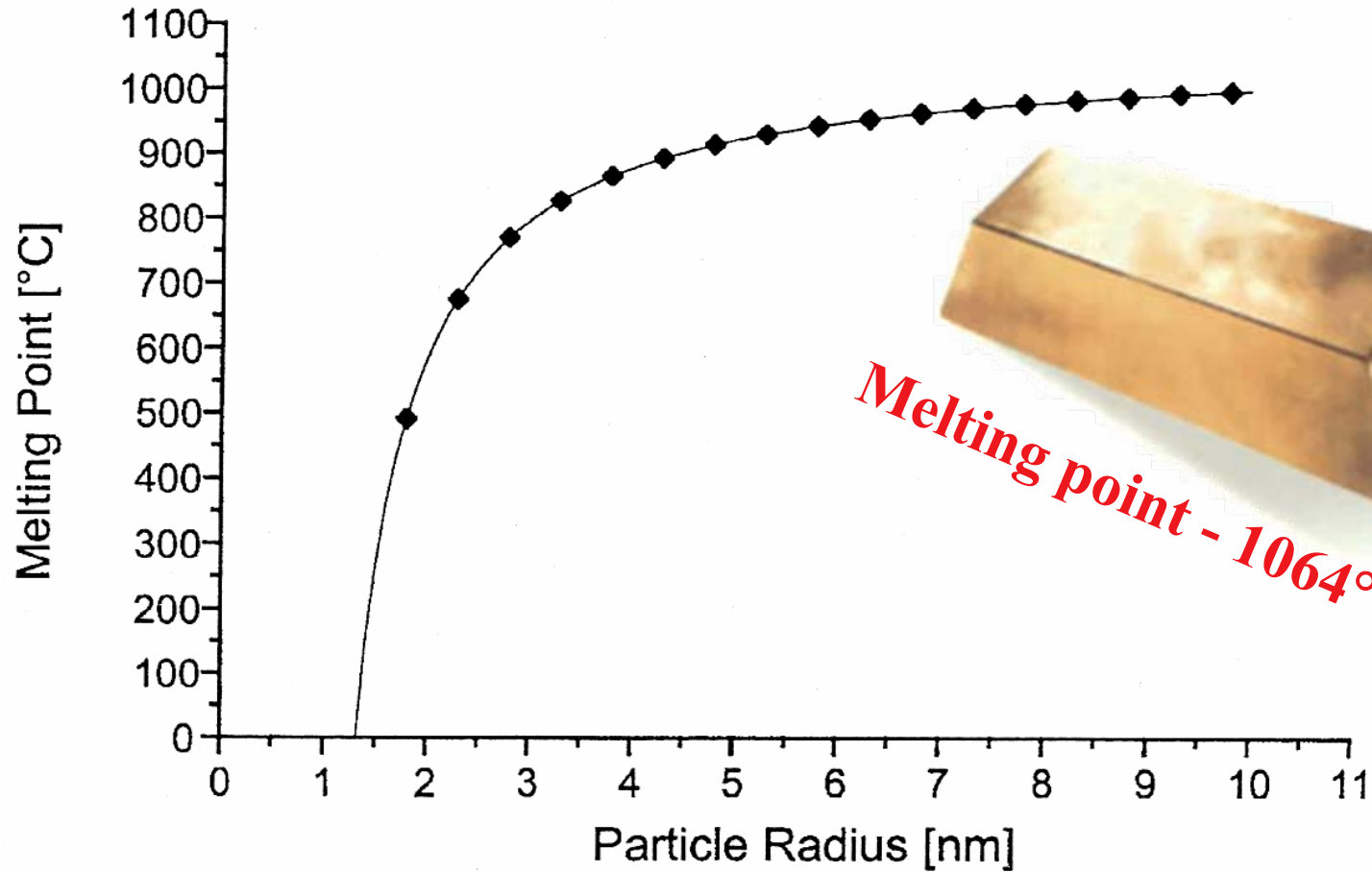

# OUTLINE

- Computing and Data Storage
- Materials and Manufacturing
- Health and Medicine
- Energy and Environment
- Transportation
- Security
- Carbon nanotubes, the way to transport electricity

# OUTLINE

- **Computing and Data Storage**
- Materials and Manufacturing
- Health and Medicine
- Energy and Environment
- Transportation
- Security
- Carbon nanotubes, the way to transport electricity

# Computing & Data storage

- Processors performance  $\times 10^6$   
(Gflops  $\rightarrow$  Pflops)
- Small mass storage devices  $\rightarrow$  multi-tera bit levels
- Smart nanosensors**: collecting, processing and communicating massive amounts of data with minimal size, weight, and power consumption
- Higher transmission frequencies : more efficient utilization of optical spectrum to provide at least 10 times the current bandwidth
- Quantum computing**

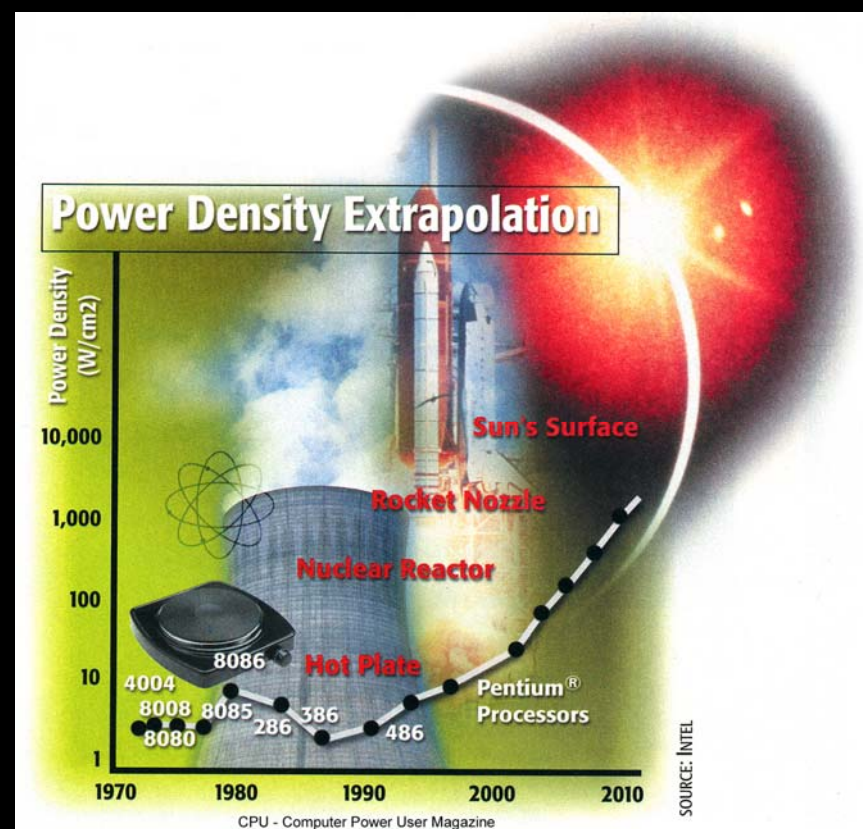

# Data storage capacity

Current data storage density  $\sim 10^9$  bits/cm<sup>2</sup>

1 bit  $\sim$  100 atoms (at the best)

Theoretical data storage capacity = X 1000 ( $10^{12}$  bits/cm<sup>2</sup>)

3D => Data storage capacity could be  $\sim 10^{16}$  bits/cm<sup>3</sup>  
( $10^{12}$  bits/cm<sup>2</sup> x  $10^4$ /cm)



# IBM Millipede

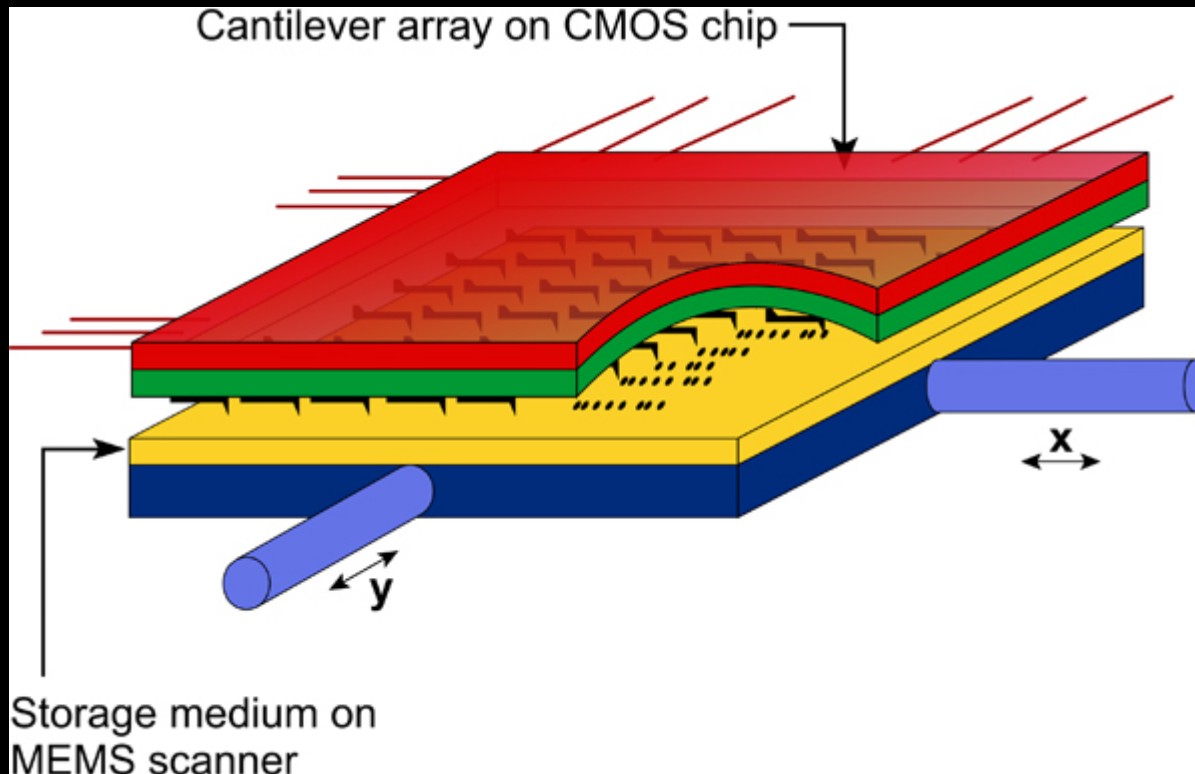

Combine the advantage of the hard disk (storage capacity, target  $\sim 1$  Tbit /in<sup>2</sup>) and the advantage of DRAM (speed access)

Principle: nanometric holes on the surface of an thermo active polymer

# IBM Millipede

$3 \cdot 10^{10}$  bits /  $\text{cm}^2$

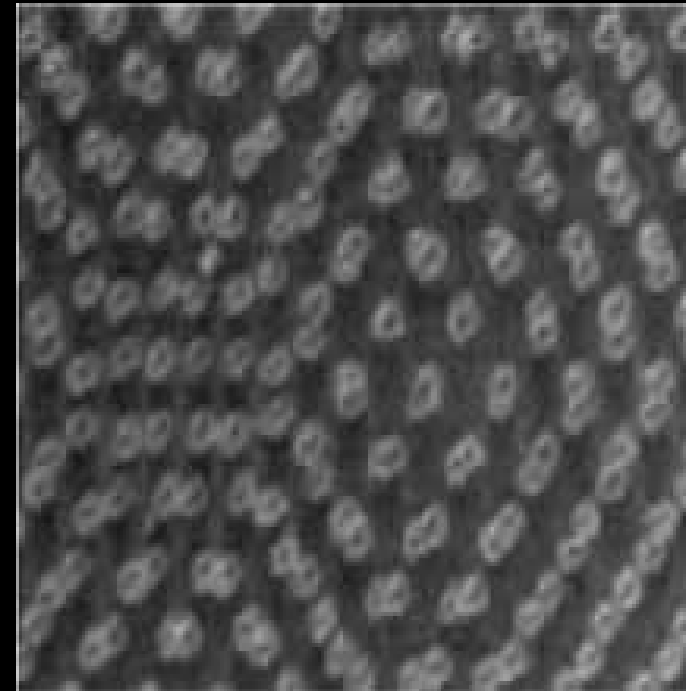

10 nm

# IBM Advanced Storage Roadmap

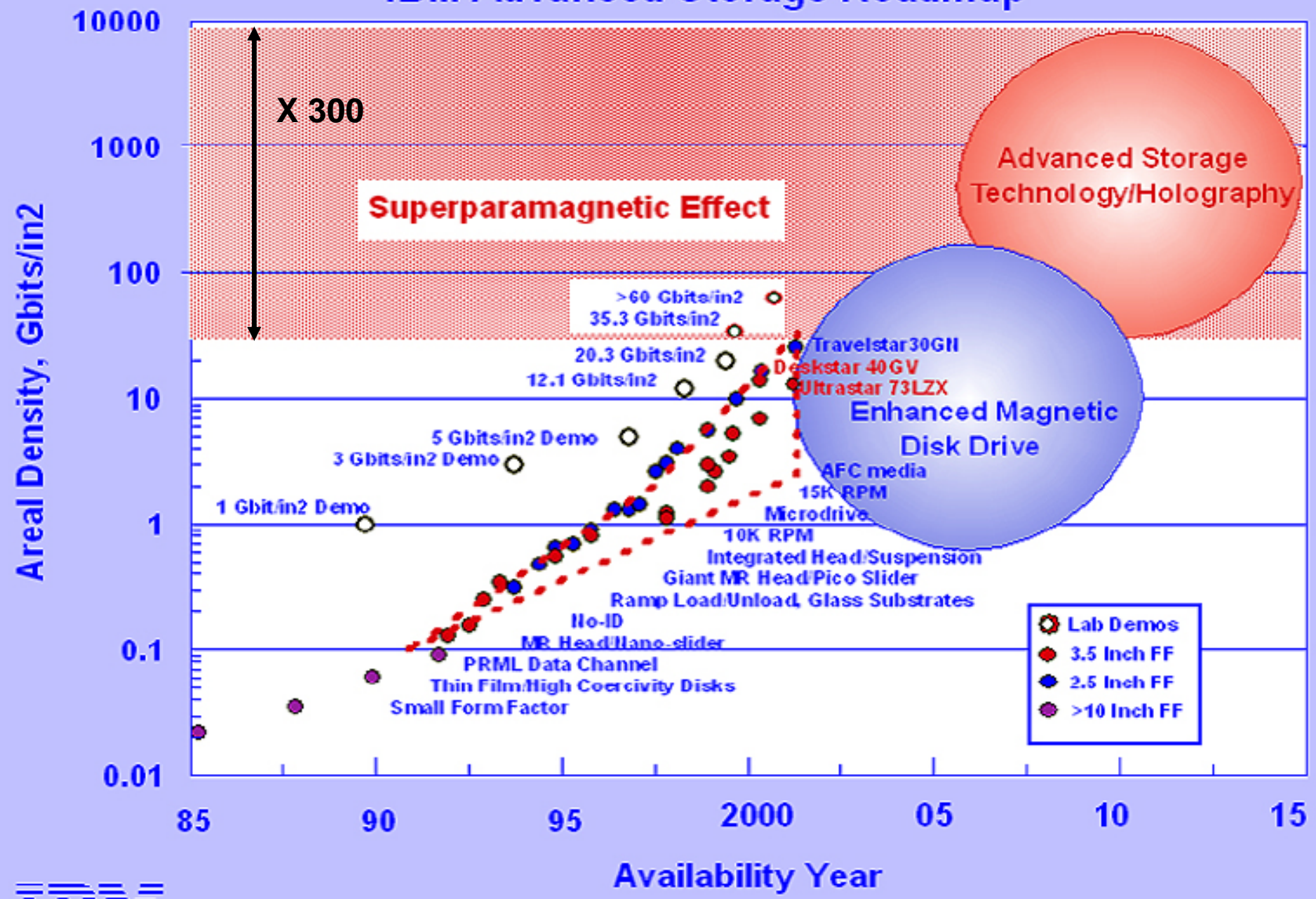

# Smart dust components / smart sensors

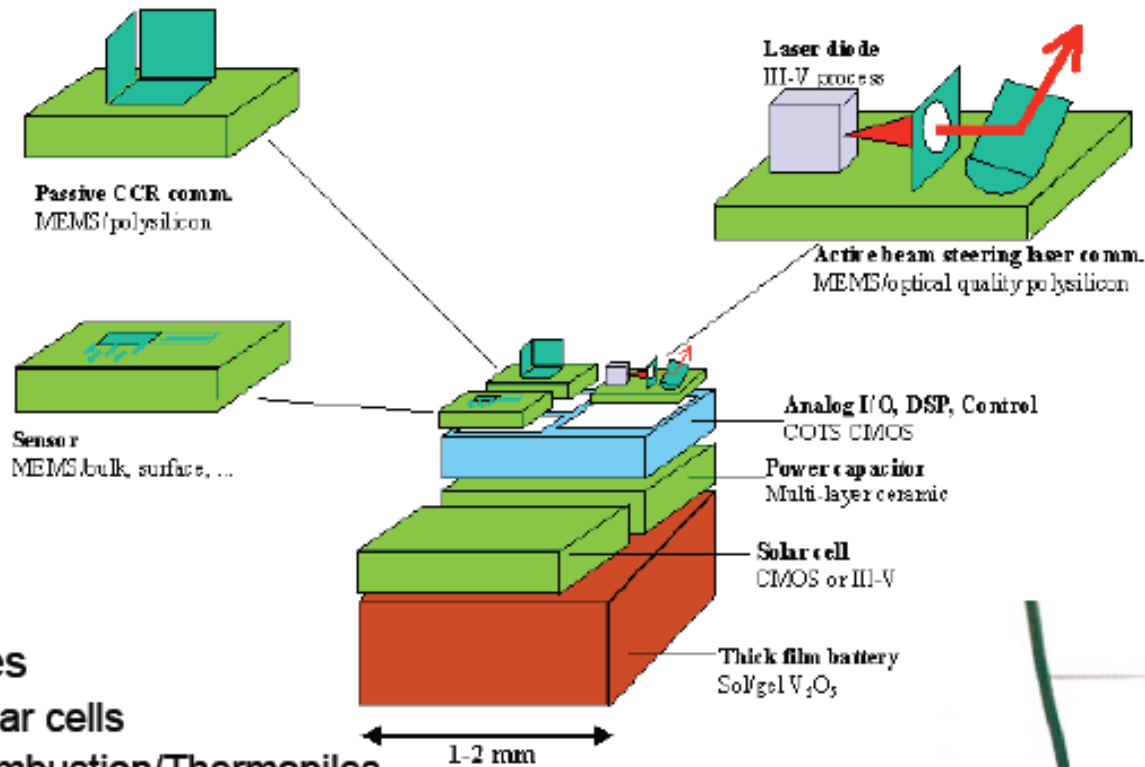

## Smart nanosensors

- Autonomous in energy
- Sensing
- Processing
- Communicating

- Sources
  - Solar cells
  - Combustion/Thermopiles
- Storage
  - Batteries  $\sim 1 \text{ J/mm}^3$
  - Capacitors  $\sim 1 \text{ mJ/mm}^3$
- Usage
  - Digital control:  $\text{nJ/instruction}$
  - Analog circuitry:  $\text{nJ/sample}$
  - Communication:  $\text{nJ/bit}$

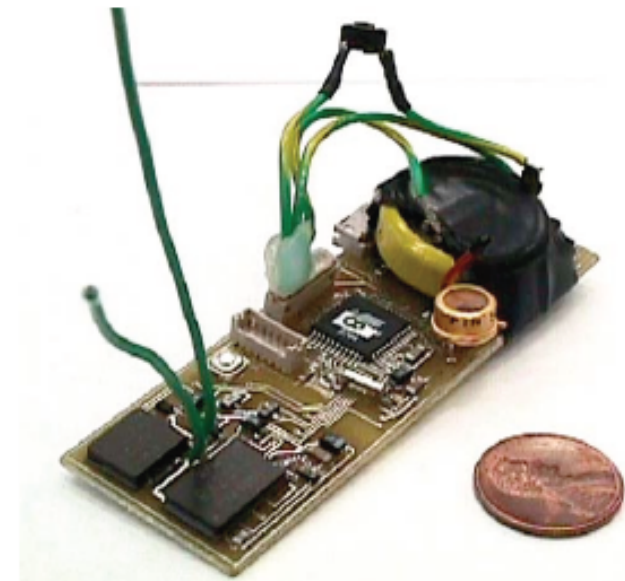



# Smart sensors

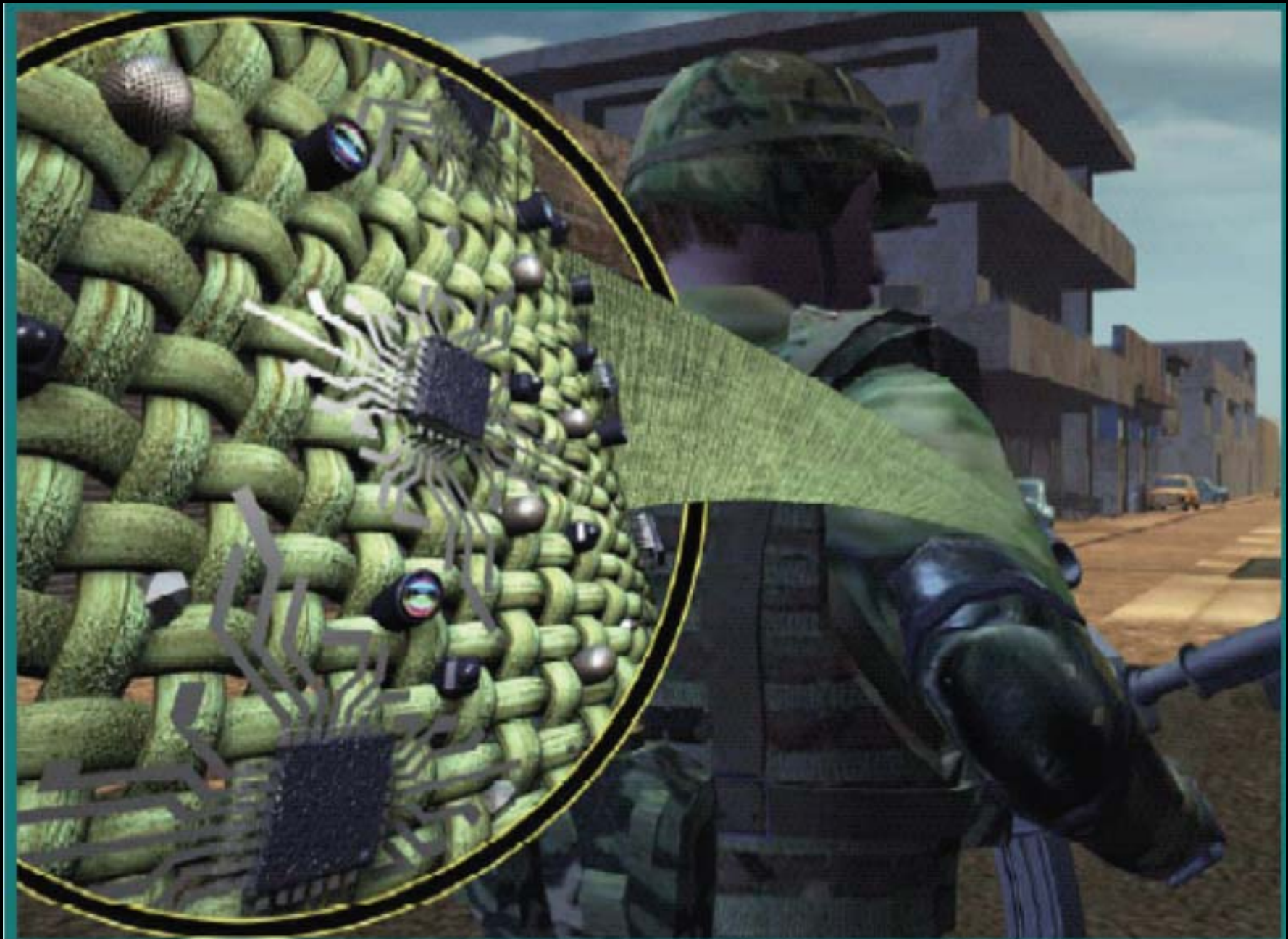

# Smart sensors on micro flyers

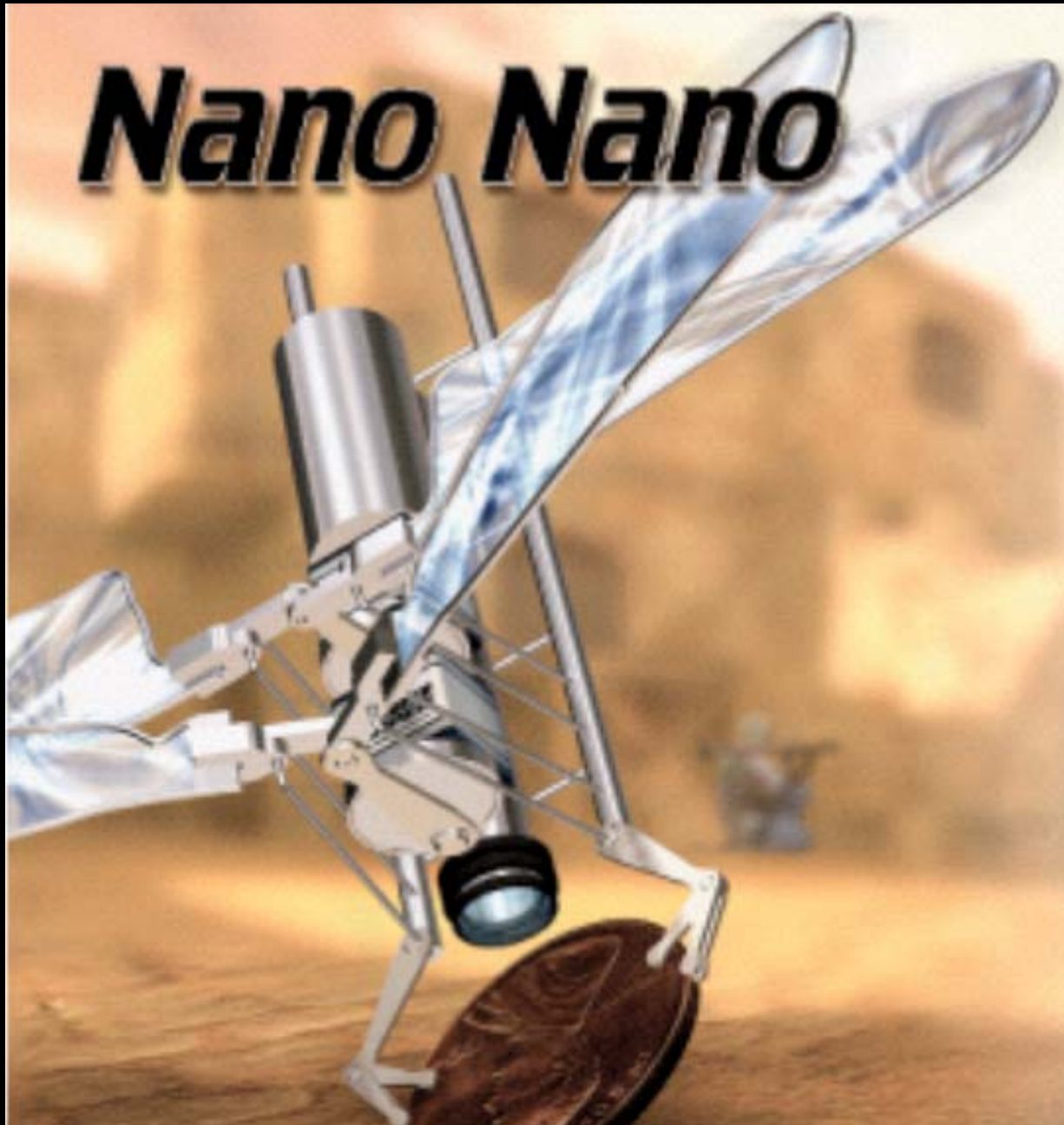

UAV  
insect size

# Quantum computing

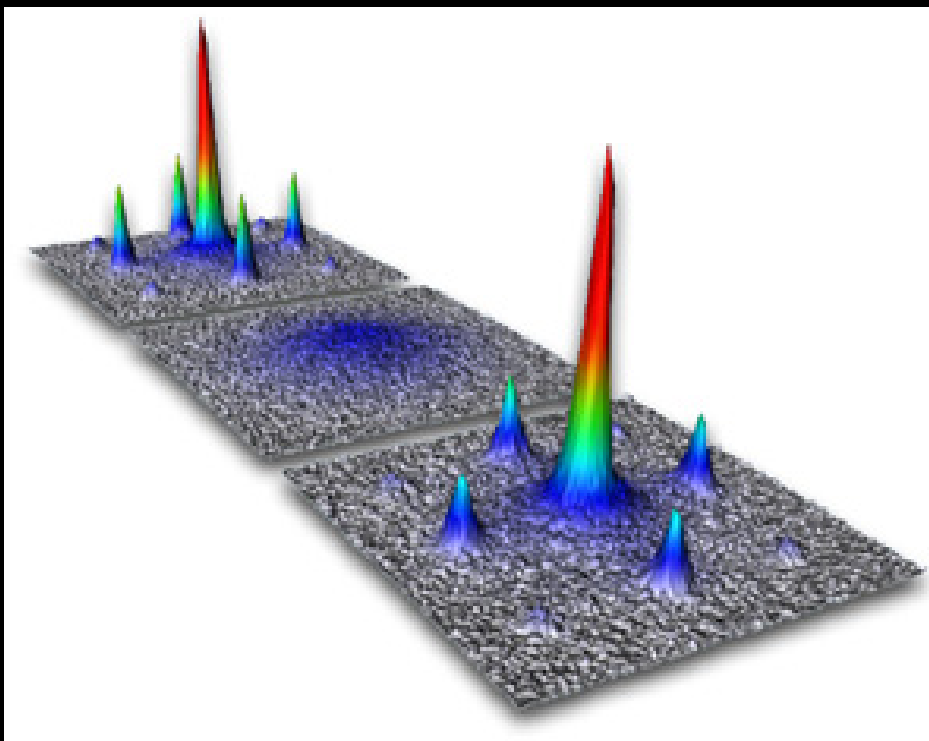

"In just 38 months, you can earn big PROFIT\$ as a fully trained QUANTUM MECHANIC!"



Learn secrets of QUANTUM MECHANICS in your own home, in your spare time, without quitting your present job!

**DO YOU HAVE WHAT IT TAKES TO BE A QUANTUM MECHANIC?**

Not just anyone can be a quantum mechanic. It takes determination, drive, imagination and money. Most of all, money. Bob is putting a son through medical school.

**NATION CRYING FOR FULLY TRAINED QUANTUM MECHANICS**

That's right, friend, the nation is crying for fully trained quantum mechanics. Can you hear it? You can't? Well be very still. Listen, off in the distance. "Waibih!" Hear that? That's the nation crying for quantum mechanics.

**QUANTUM MECHANICS EAT STEAK**

Yep, quantum mechanics make big bucks. Heavy bread. They're rolling in dough. They carry big wads of 10's and 20's in their pockets. A lot of MONEY. They drive Cadillacs and buy their wives minks. And they eat steak.

**THIS COURSE TEACHES YOU ALL YOU NEED TO KNOW EVERYTHING. THERE ISN'T A SINGLE THING ABOUT QUANTUM MECHANICS LEFT OUT.**

Wrong, electron breath! But it's close. We teach you a whole bunch of stuff. Mesatron balancing. Quark realignment. Neutrino lubrication. Proton tune-up. How to use a molecule wrench.

**YOU GET PROFESSIONAL EQUIPMENT TO LEARN WITH**

You will receive a professional cyclotron, actual atoms, a year's supply of Preparation A for your atomic piles, back issues of Scientific American to July, 1957 and a bill for your mailman's hernia operation. Not to mention our bill for \$675. Which is cheap when you consider how proud you'll be to hear your son say, "My daddy's a Quantum Mechanic!"

**—GUARANTEE—**

I hereby guarantee that, without a doubt, this is the only course of its kind in the world. You'll be completely satisfied, or I'll cheerfully keep your money.

Bob

**LISTEN TO WHAT THESE SATISFIED CUSTOMERS SAY!**

**"Like, you know, this course, you know, I like, uh, expanded my consciousness, you know. And I need all the consciousness I can get, you know?"**  
PAT HEAD, San Francisco, Cal.

**"One of my most proud moments was getting my diploma last May. I enrolled right after the war. That was the Big One, son, W.W. II!"**  
"POP" CHERRY, Sun City, Ariz.

**"I used to be Prime Minister of a major European nation. Then I took this course. Now I drive a big car, eat steak, and make over \$6.00 an hour!"**  
HARRY DEAN II, Tater, Ark.

**NO RISK!**

You get this Professional cyclotron with your course—and it's **YOURS TO KEEP!**

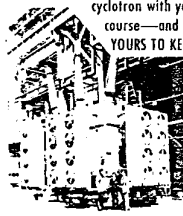

Send NOW for this FREE BROCHURE!

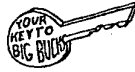
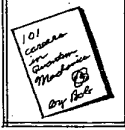

NO OBLIGATION - NO SALESMAN WILL CALL

**Bob's School of QUANTUM MECHANICS**

A DIVISION OF BOB'S CONOCO SERVICE STATION  
7036 STATE ROAD 29  
EAST BELCH, NORTH DAKOTA 51106  
•Approved by Peruvian Ministry of Agriculture  
•Approved by Bob



**MAIL COUPON NOW**  
Bob's School of Quantum Mechanics  
7036 State Road 29  
East Belch, ND 51106

Dear Bob,  
Enclosed please find my \$16.95 in cash (no check or money order, please). PLEASE RUSH me my FREE BROCHURE on an exciting career in QUANTUM MECHANICS. I understand if I am not completely satisfied, I have been had.

Name \_\_\_\_\_  
Address \_\_\_\_\_  
City/State/Zip \_\_\_\_\_

**APPROVED FOR VETERANS**  
of the Spanish-American War

Reprinted from Physics Equipment Magazine



# Schrödinger's cat

*Take a cat, cyanide, a radioactive particle, put the whole in a box and let wait one hour!*

Letter from Schrödinger to Einstein, 1935

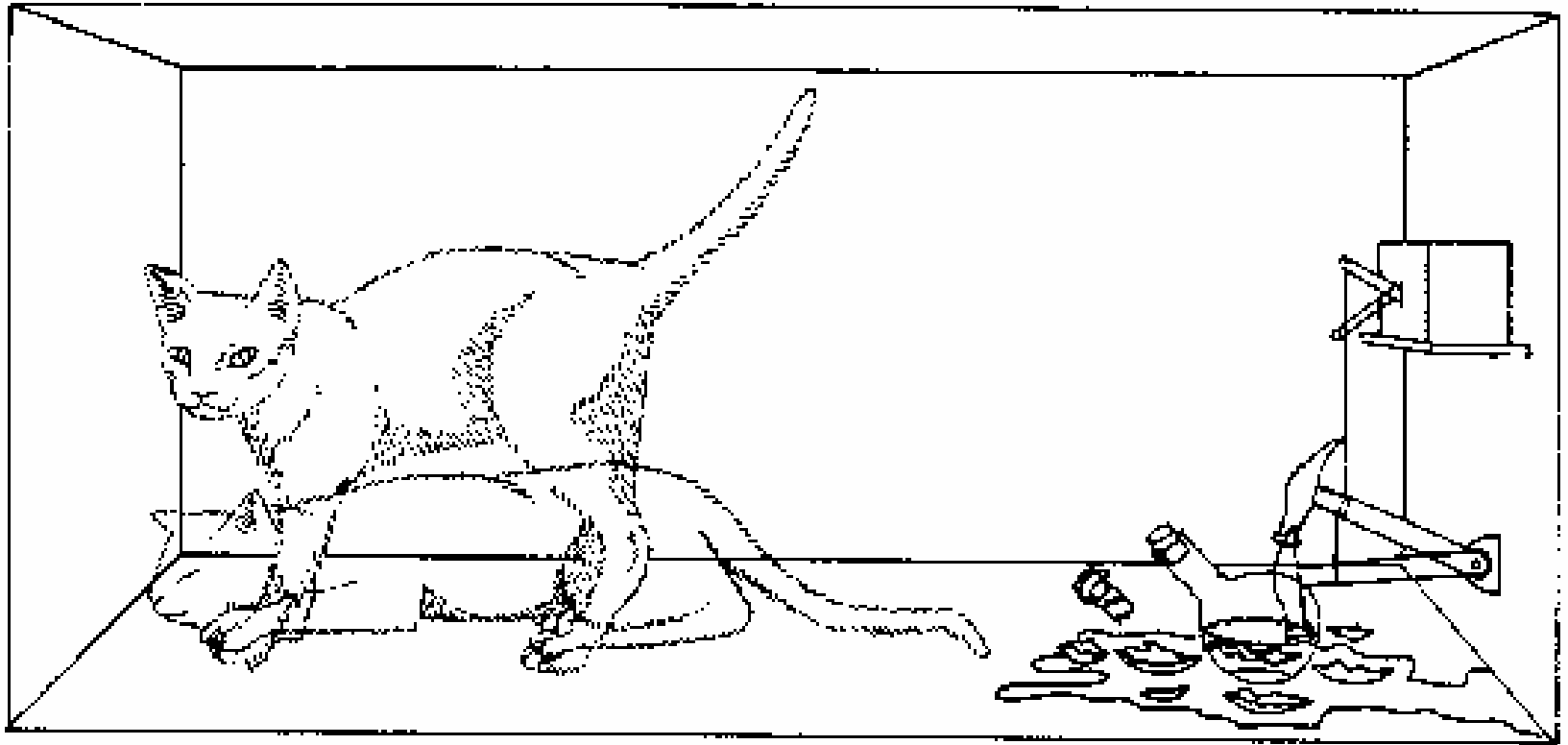

$$|\psi\rangle = \frac{1}{\sqrt{2}} |\text{Dead cat}\rangle + \frac{1}{\sqrt{2}} |\text{Alive cat}\rangle$$



# Quantum computing

A traditional bit is **1** or **0**

A Quantum bit (Qubit) is a superposition of state **1** and **0**

$$|\psi\rangle = \alpha|0\rangle + \beta|1\rangle$$

$$(0 \leq \alpha \leq 1 \text{ and } 0 \leq \beta \leq 1)$$



# Quantum computing

## *Is it SF ?*

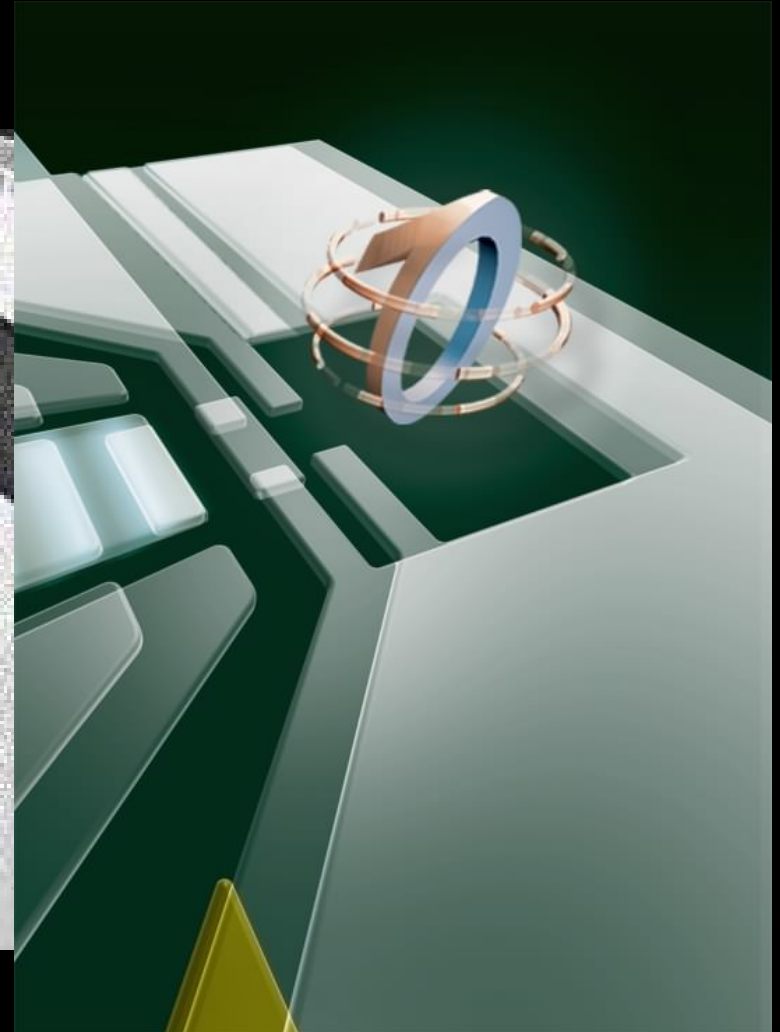
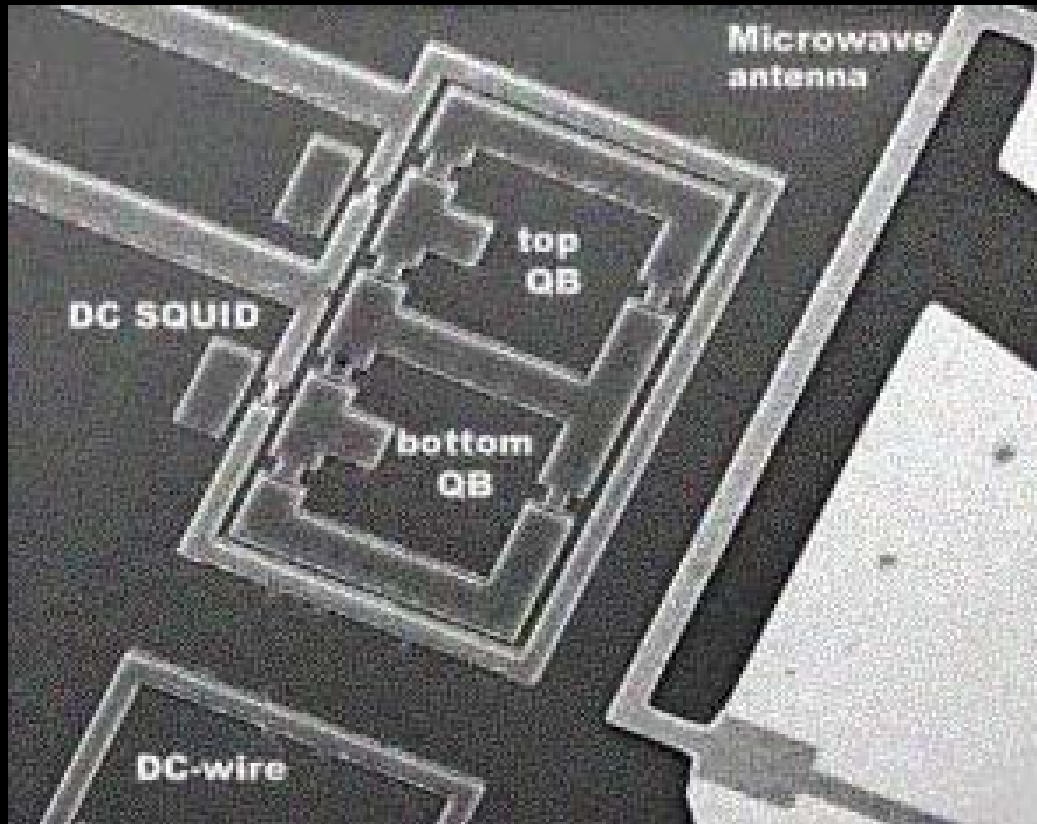

# Quantum computing

## *Shor's algorithm (1995)*

Principle of RSA cryptography: factorization of a number

The solution is easy to verify (multiplication) but difficult to find (factorization in prime number)

Example:

Classical computing: three months to factorize a number of 130 digits and  $10^{10}$  years (the age of the Universe) for a number of 400 digits

Quantum computing: still three months to factorize a number of 130 digits but only 3 years for a number of 400 digits!

# Quantum computing

## *First tentative*



Qubit Ion trap  
(NIST)

Qantronium super conducting qubit  
(CEA)

Quantum computing is not for  
tomorrow !

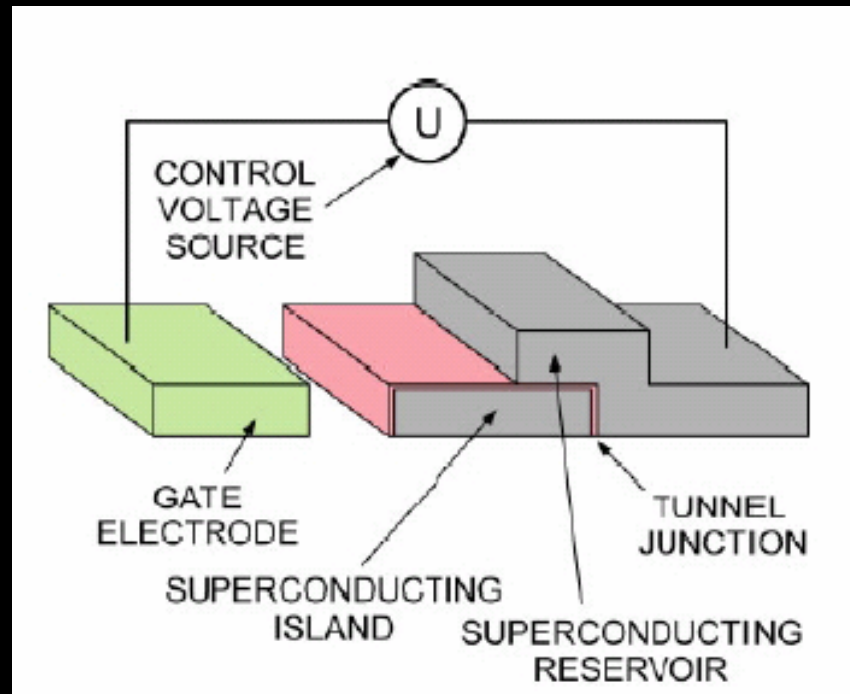

# Quantum cryptography



**Quantum key distribution**  
**Quantum random number generator**

## Key distribution over optical fiber with absolute security

### Main features

- ▶ First quantum cryptography system
- ▶ Security guaranteed by quantum physics
- ▶ Point-to-point key distribution
- ▶ Standard optical fiber
- ▶ Distances up to 70 km
- ▶ Key rate up to 1000 bits/s
- ▶ Compact and reliable

Key distribution is a central problem in cryptography. Currently, public key cryptography is commonly used to solve it. However, these algorithms are vulnerable to increasing computer power. In addition, their security has never been formally proven.

Quantum cryptography exploits a fundamental principle of quantum physics - observation causes perturbation - to distribute cryptographic keys with absolute security.

id Quantique is introducing the first quantum key distribution system. It consists of an emitter and a receiver, which can be connected to PC's through the USB port.

### id Quantique

10, rue Cingria, 1205 Genève, Switzerland  
Tel: (+41) 022 702 89 29 Fax: (+41) 022 781 00 80  
email: info@idquantique.com  
web: <http://www.idquantique.com>



*Example: Idquantique (start up) : [www.idquantique.com](http://www.idquantique.com)*

**Quantum cryptography already exists :**  
**60 km with OF ; 150 km with free space transmission**

# OUTLINE

- Computing and Data Storage
- **Materials and Manufacturing**
- Health and Medicine
- Energy and Environment
- Transportation
- Security
- Carbon nanotubes, the way to transport electricity

# Materials and manufacturing

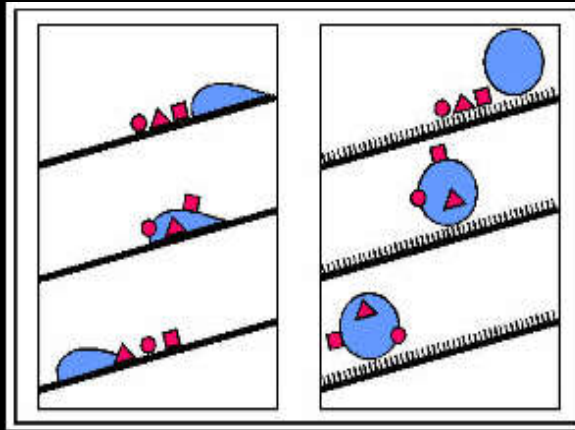

Self-cleaning surface  
(lotus effect)

*W. Barthlott, Univ. of Hamburg*

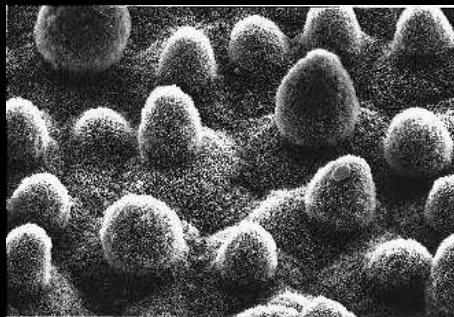

Epicuticular wax



*(Source: Metin Sitti, CMU)*



# Self-cleaning surface

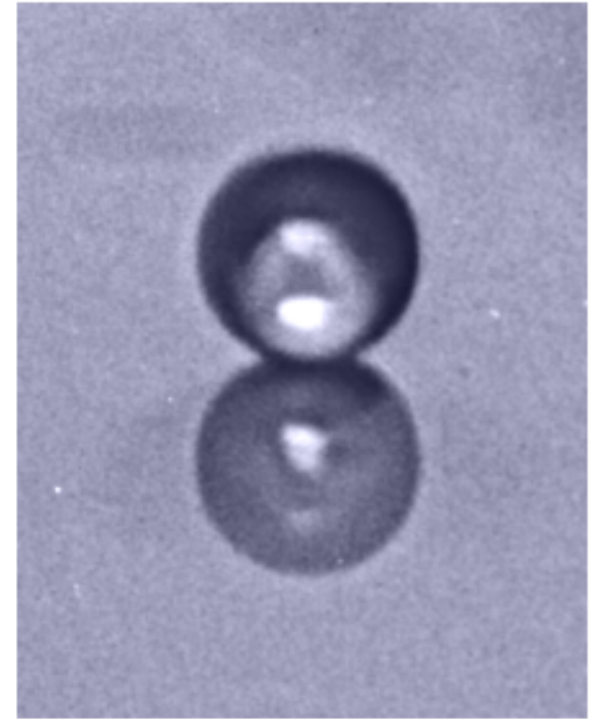
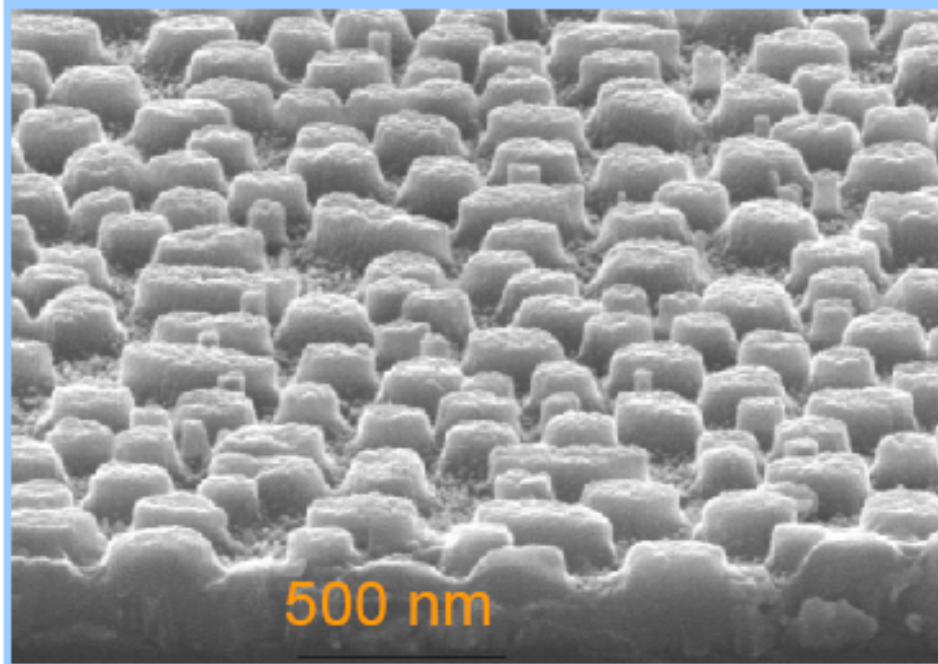

Nano relief => the water does not wet



# Self-cleaning glass



Pilkington's self-cleaning glass

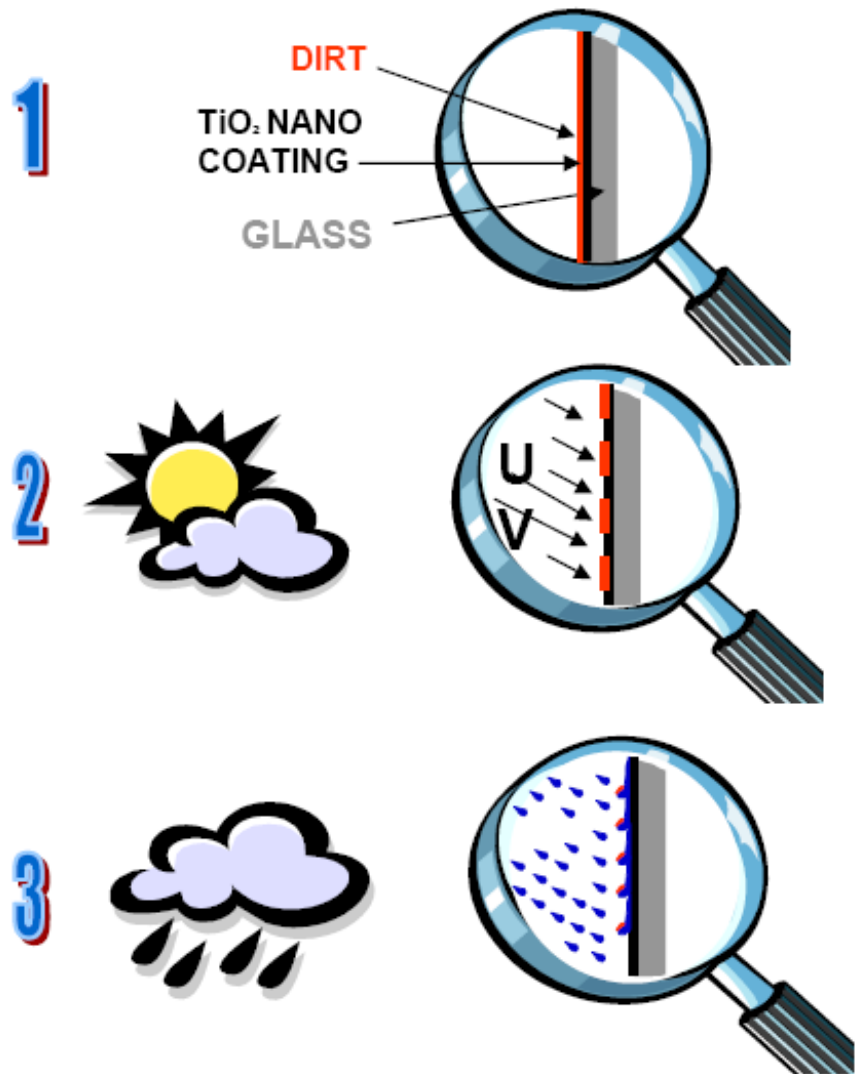

# SPACEDAILY

YOUR PORTAL TO SPACE

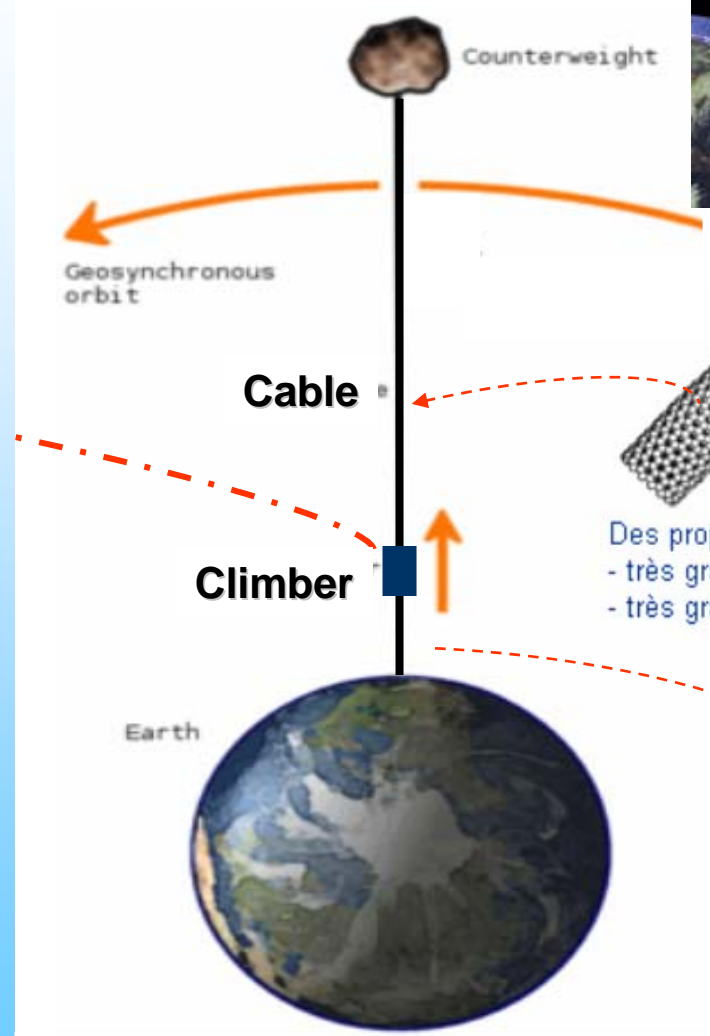

## Carbon nanotubes



Des propriétés mécaniques hors du commun :

- très grande élasticité (module d'élasticité > 1000 GPa),
- très grande flexibilité (crack stress : 45 GPa)

A space elevator would consist of a cable attached to the surface and reaching

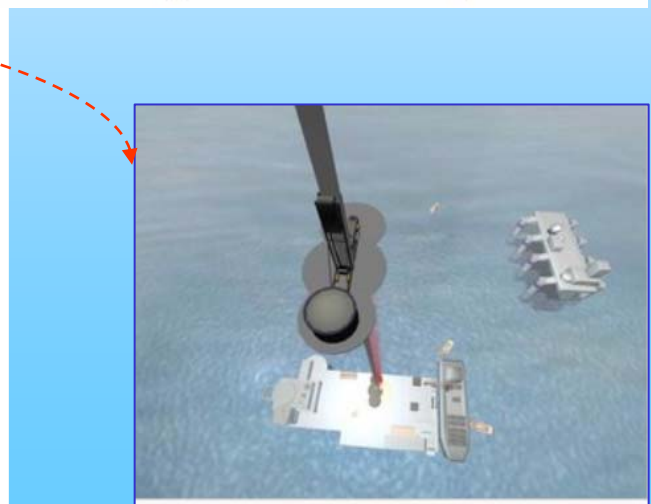

One concept for the space elevator has it tethered to a mobile sea-going platform.

# Space elevator

Edwards Bradley's project :  
The satellite is placed in orbit  
thanks to the CNT cable

The satellite is pushed  
thanks to the ground laser  
which strike the solar panels  
installed under the platform

Estimated cost ~ 6 billion \$  
for the first project

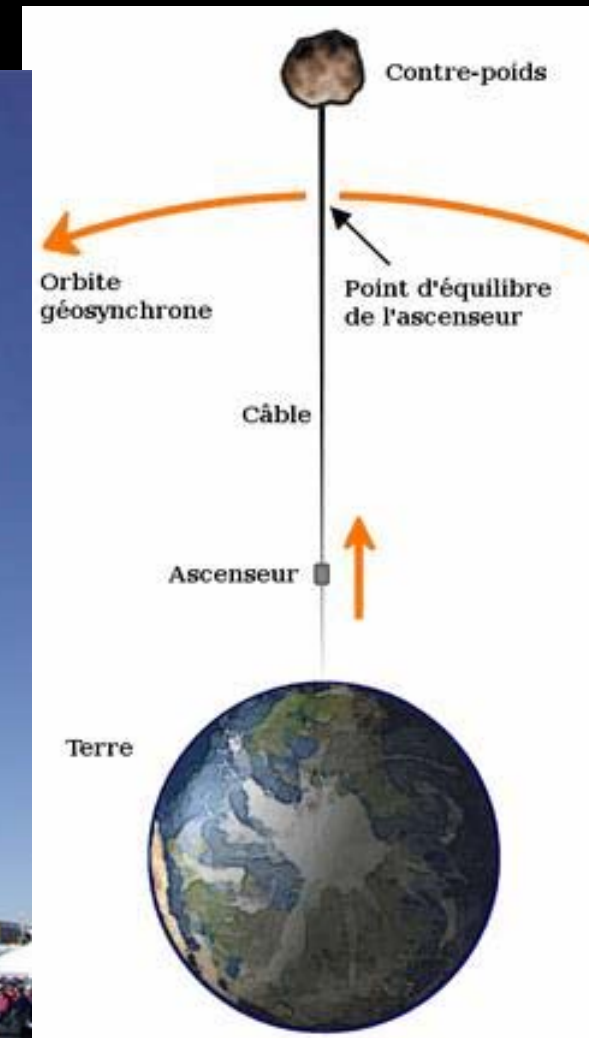

# Nano ceramic

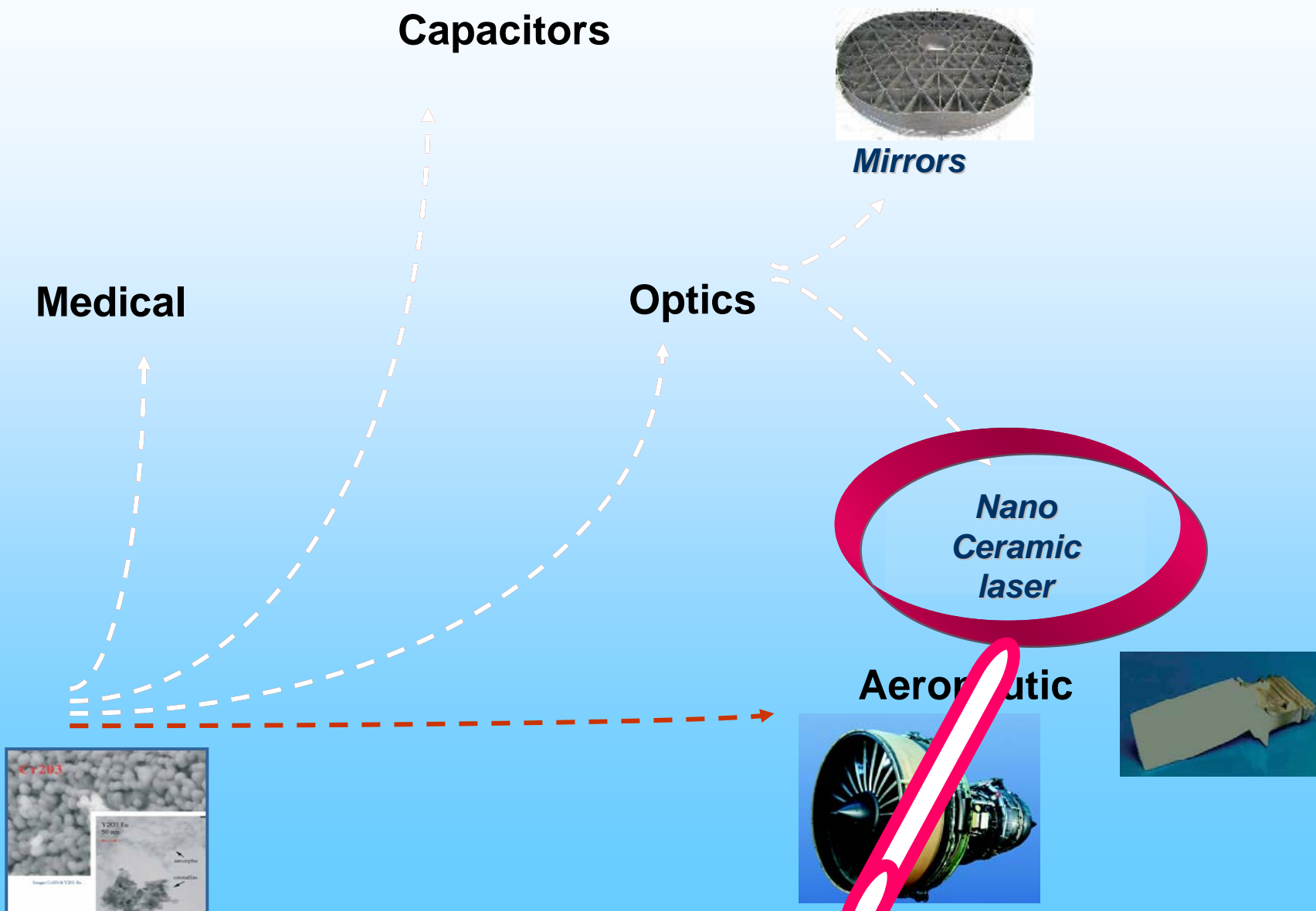

# Nano ceramic

*When the wave length is of the order of the size of the grains of the ceramic, the light is not scattered in material*

light

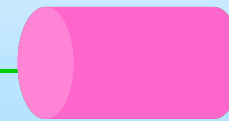

Nano  
Ceramic

YAG

$Y_3Al_5O_{12}$   
: Nd

# Nano ceramic

Capacitor

Medical

Optics

Mirrors

Nano Ceramic laser

Aeronautic

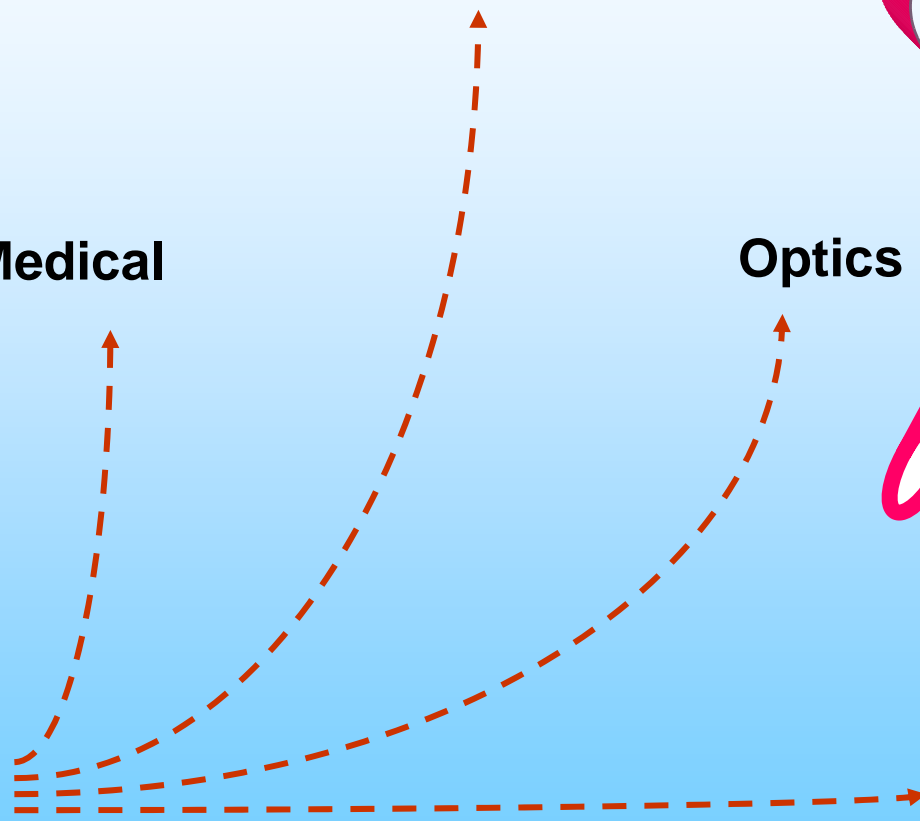
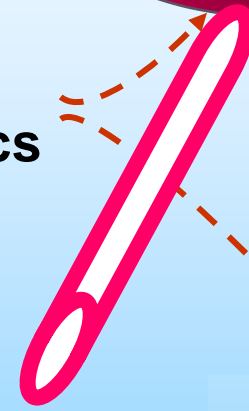



## Mirrors for space application

**Glass :**  
**60 kg / m<sup>2</sup>**

*Yesterday*



**CeSiC :**  
**25 kg / m<sup>2</sup>**



**12 kg / m<sup>2</sup>**

*Today*

*Future*

# Nano ceramic

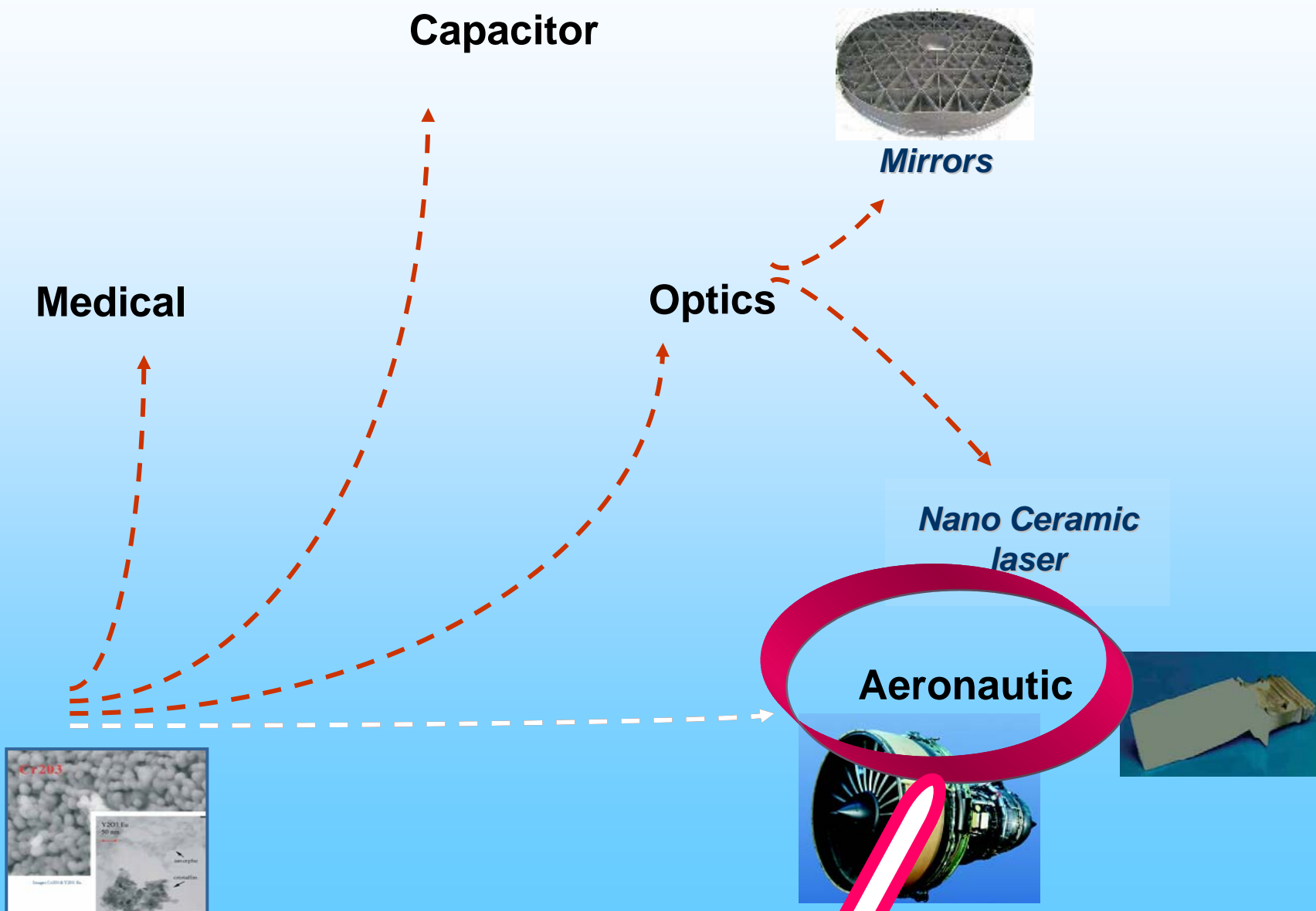

Mirrors





# Jet

GP7200

Various heat-resistant materials and alloys

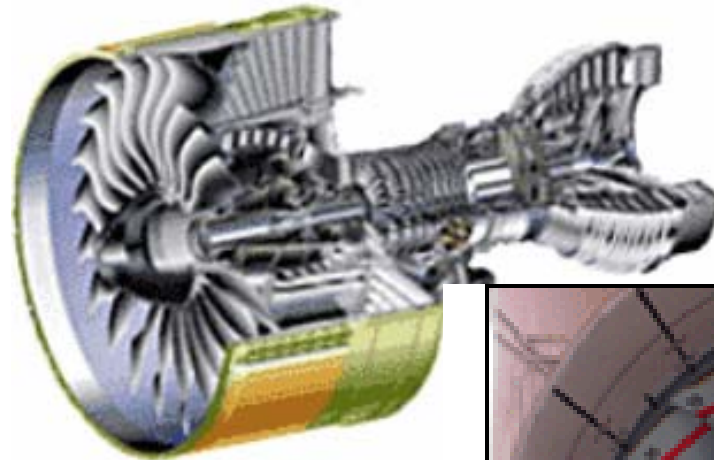

- ~ Titanium
- ~ Ti6A4V
- ~ Ti6A4V with SiC

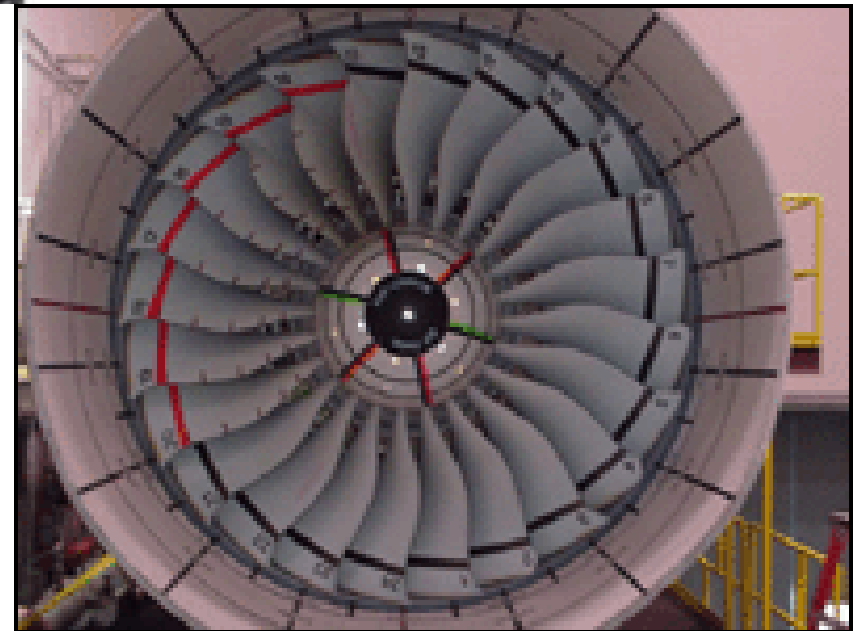

GP 7200 jet for A380

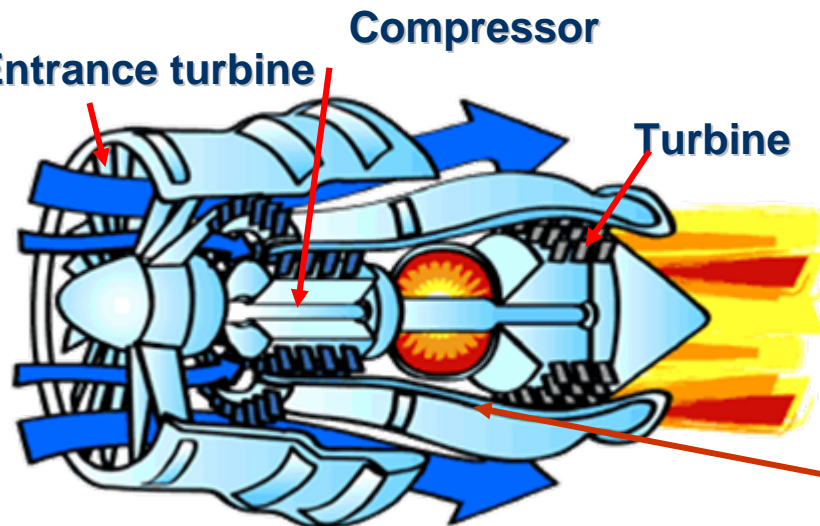

Composite combustion chamber containing **nanoparticules** **ceramics**

# OUTLINE

- Computing and Data Storage
- Materials and Manufacturing
- **Health and Medicine**
- Energy and Environment
- Transportation
- Security
- Carbon nanotubes, the way to transport electricity

# Health and Medicine

This nanoscopic “submarine” could, in the near future, penetrate in the blood vessels to destroy microbes, to correct genetic errors, to remove cancerous cells and to repair tissue

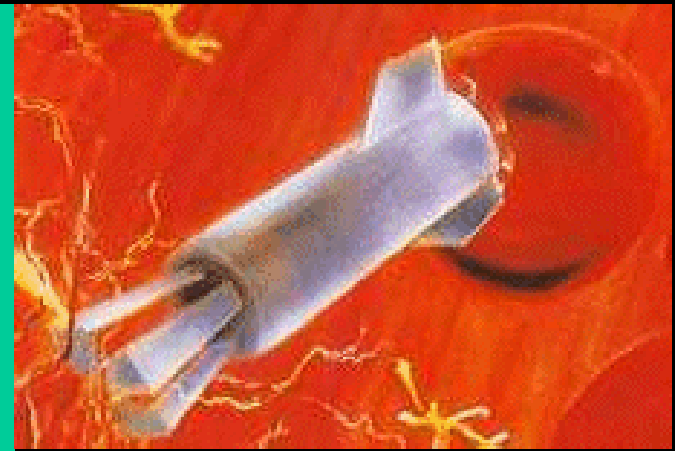

**An artificial carrier**  
e.g. a carbon nanotube

**Drugs** (genes for cell transfection)

**A coating**  
able to dissolve intra or extra-cellularly, depending if the drug release is inside or outside the cell

**Cell ligands,**  
able to bind a surface receptor of the target cell to transfect

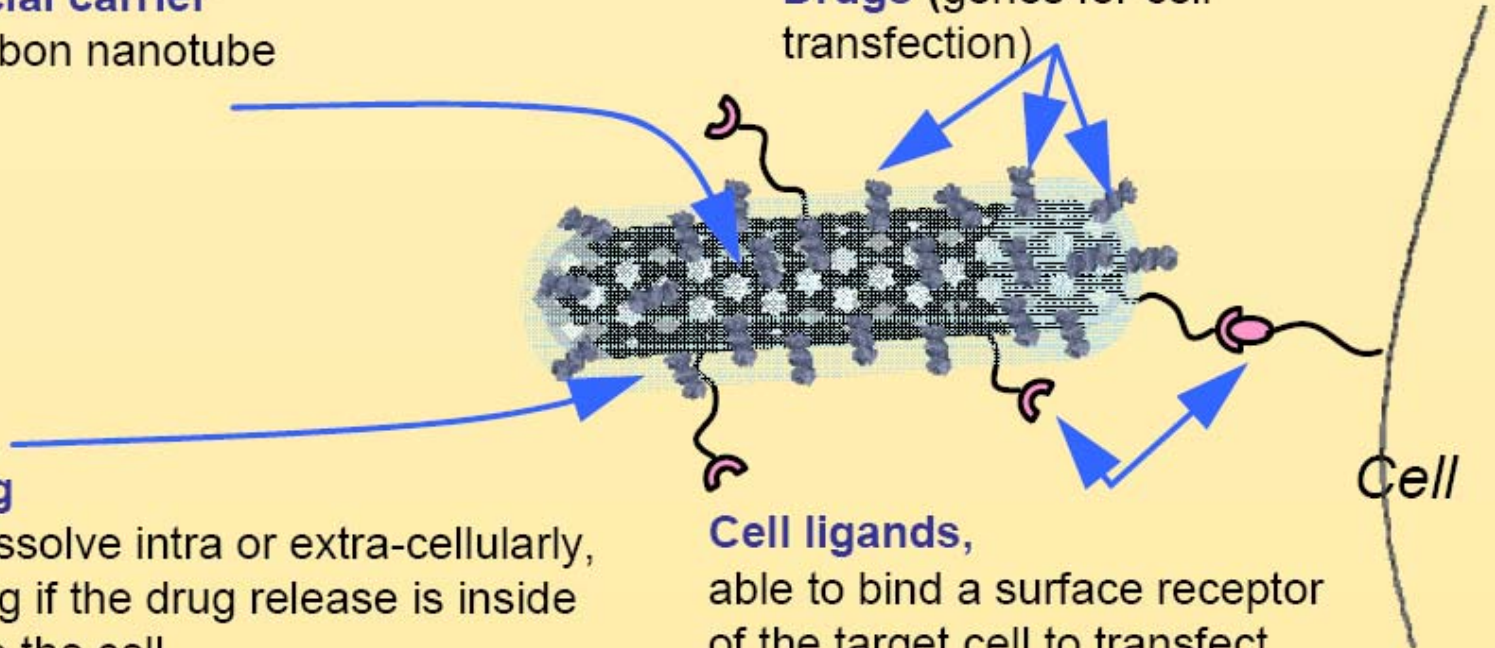

# Health and Medicine

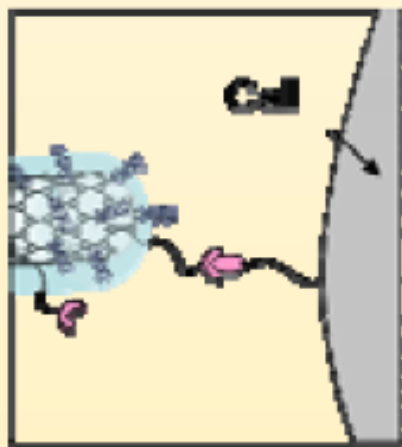

The cellular vector binds the target cell

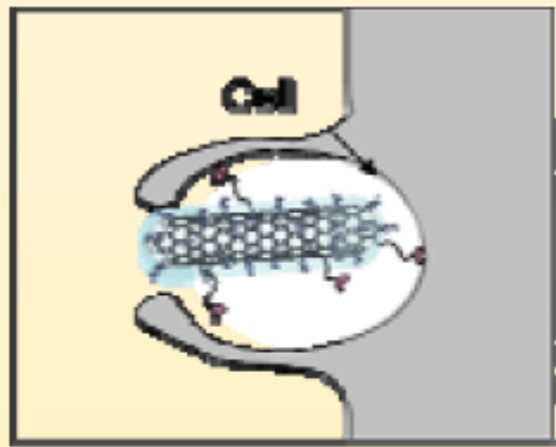

The cell phagocytoses the vector

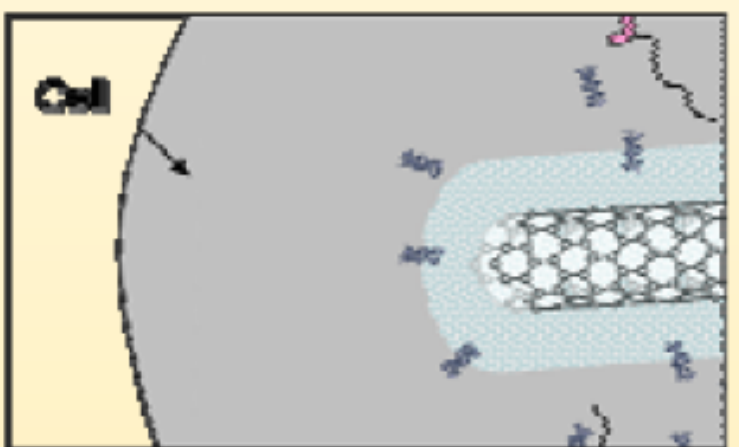

The vector has been up-taken by the cell: the coating dissolves and the genes are released

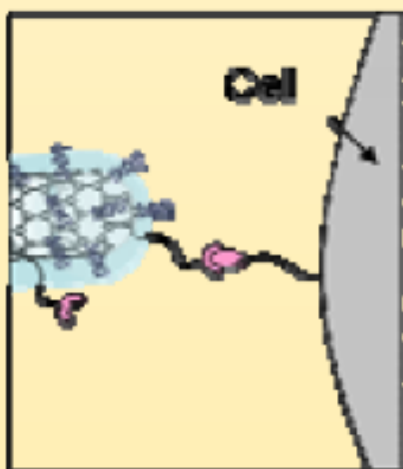

Cellular vector - cell binding

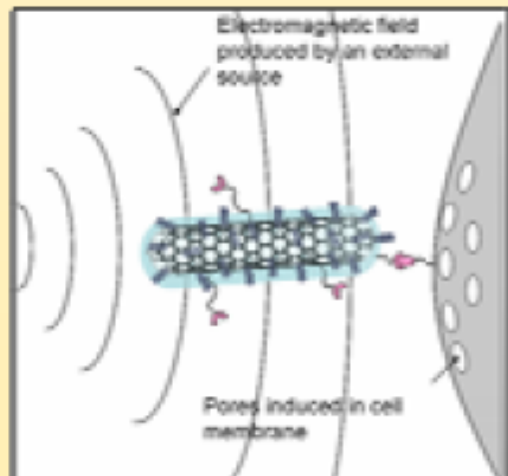

Cell electroporation via the cellular vector

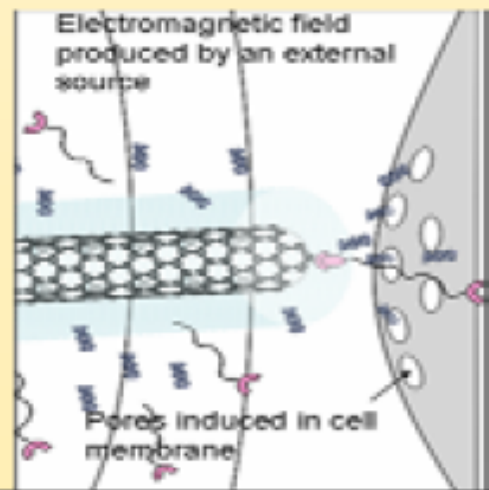

The coating dissolves, genes are released and diffuse across the pores

# Health and Medicine

## *Detection of cancerous cells*

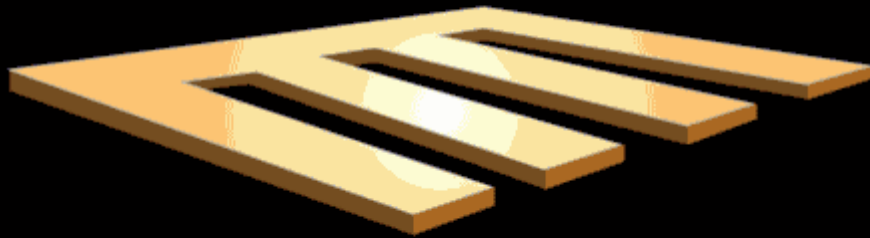

### Diagnosis of cancer

The cantilevers can facilitate the diagnosis of cancer when they bind to the cancerous molecules

**Diagnosis of mellitus diabetes**  
Detection of acetone in the breath of the patient

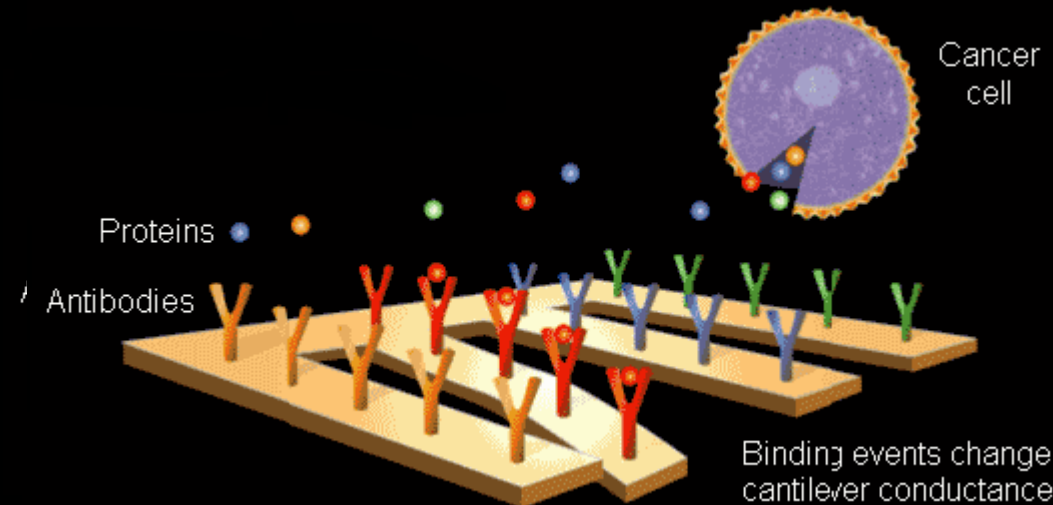

# Health and Medicine

## *Electric detection of virus in solution by nanowire field-effect transistors*

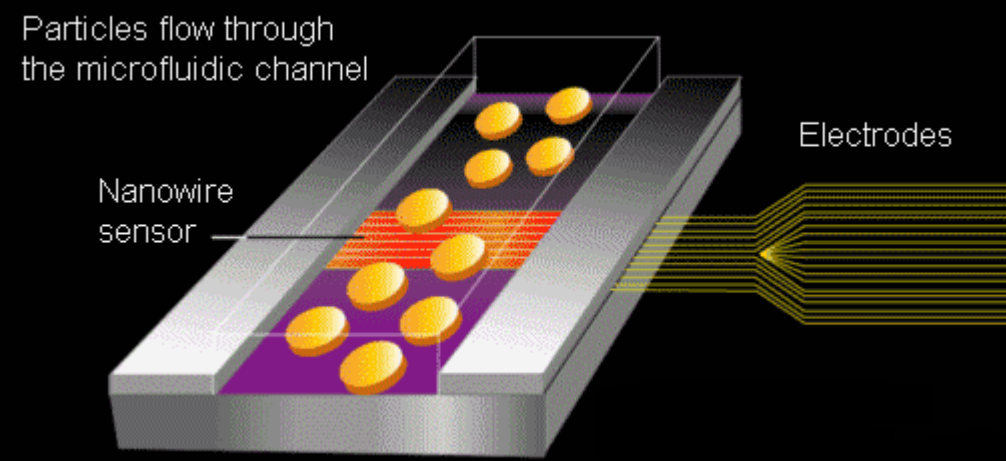
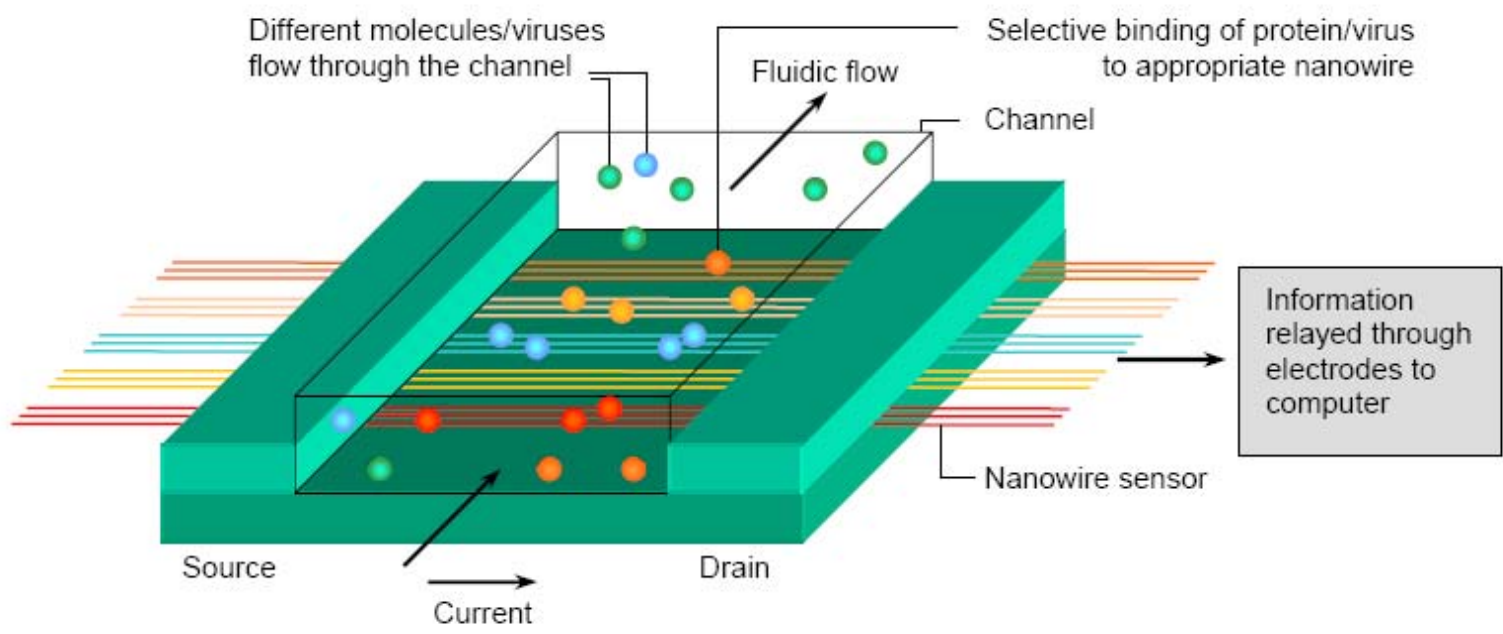



# Health and Medicine

**Administration of drug  
by micro syringe  
(e.g. insulin)**

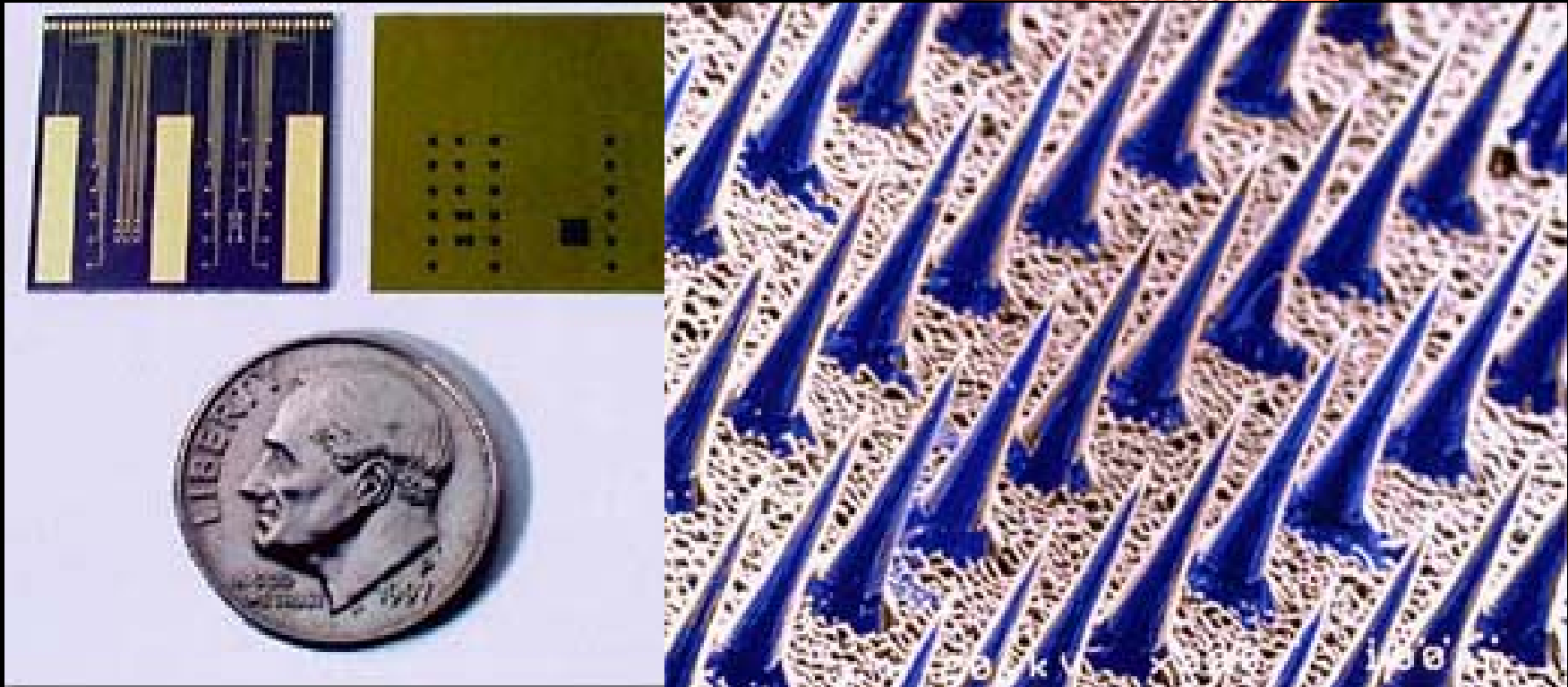
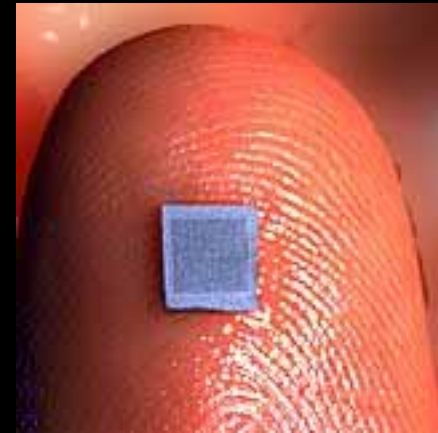

# Health and Medicine

*Implant materials, bones repair*

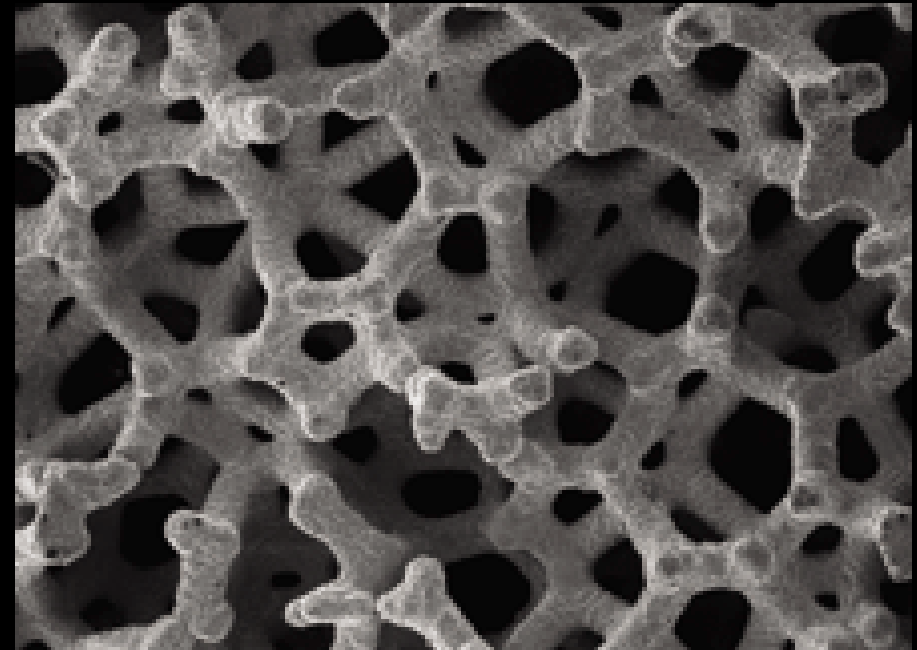



# Health and Medicine

## *Bio resorb materials*

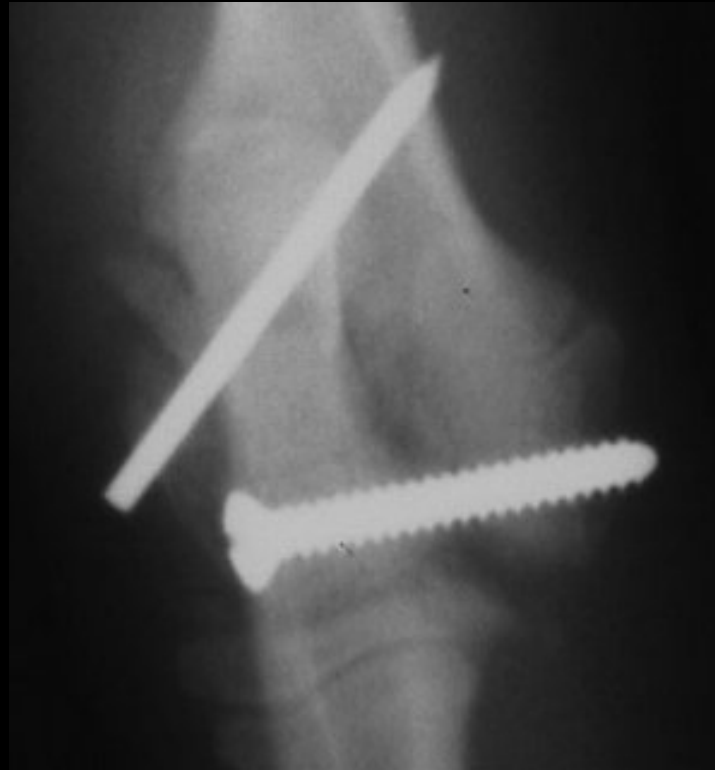

# Health and Medicine

## *Vision aid, retinal implant*

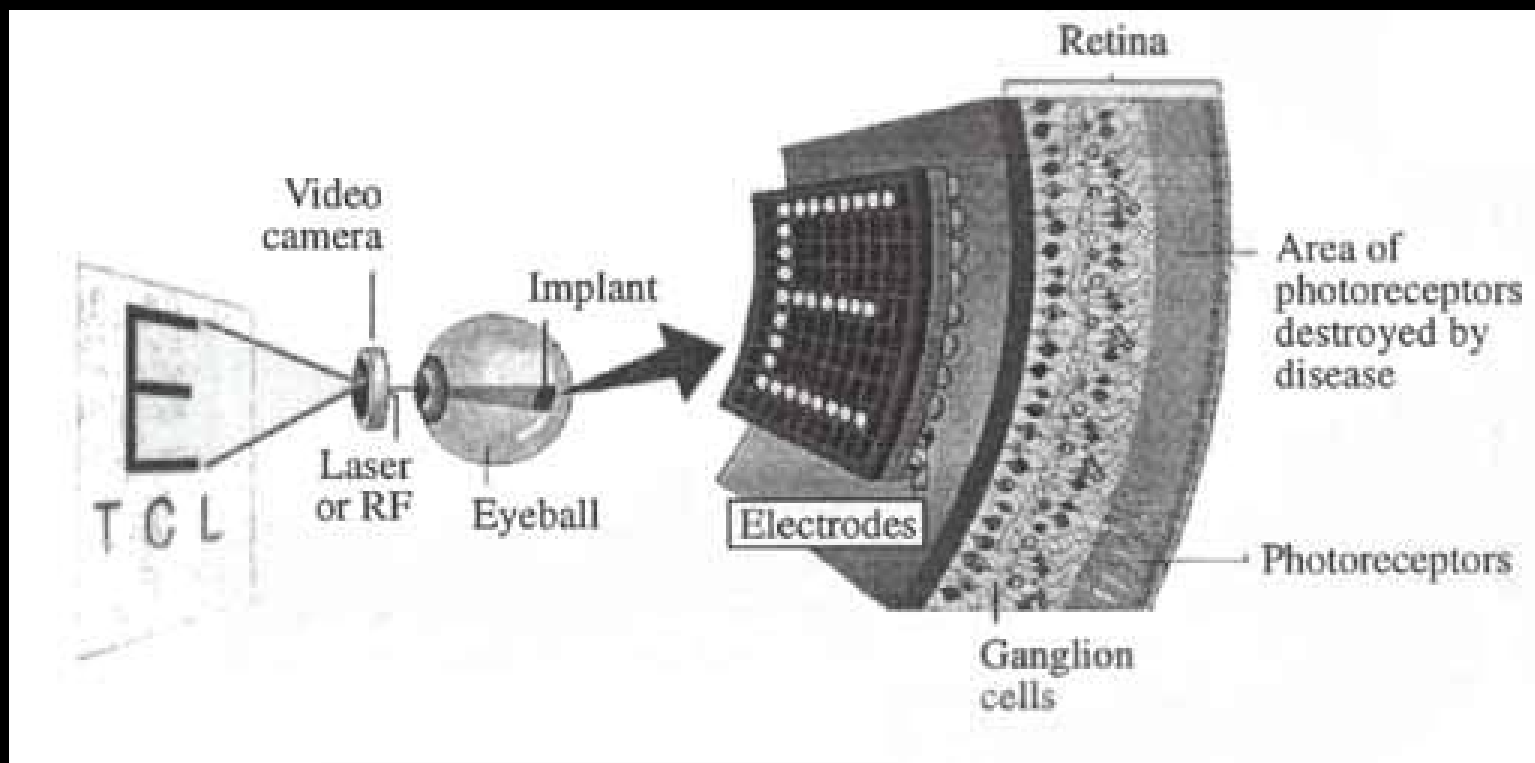

# Health and Medicine

## *Vision aid, retinal implant*

The interface with the neurons is made by microfluidic channels; stimulations are carried out by chemical ways

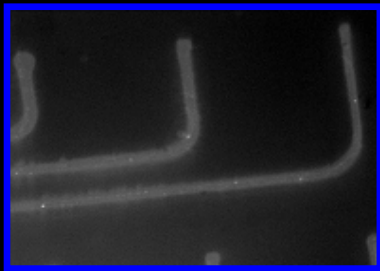

**Micro-Si probe array**

**Signal Processing Circuit**

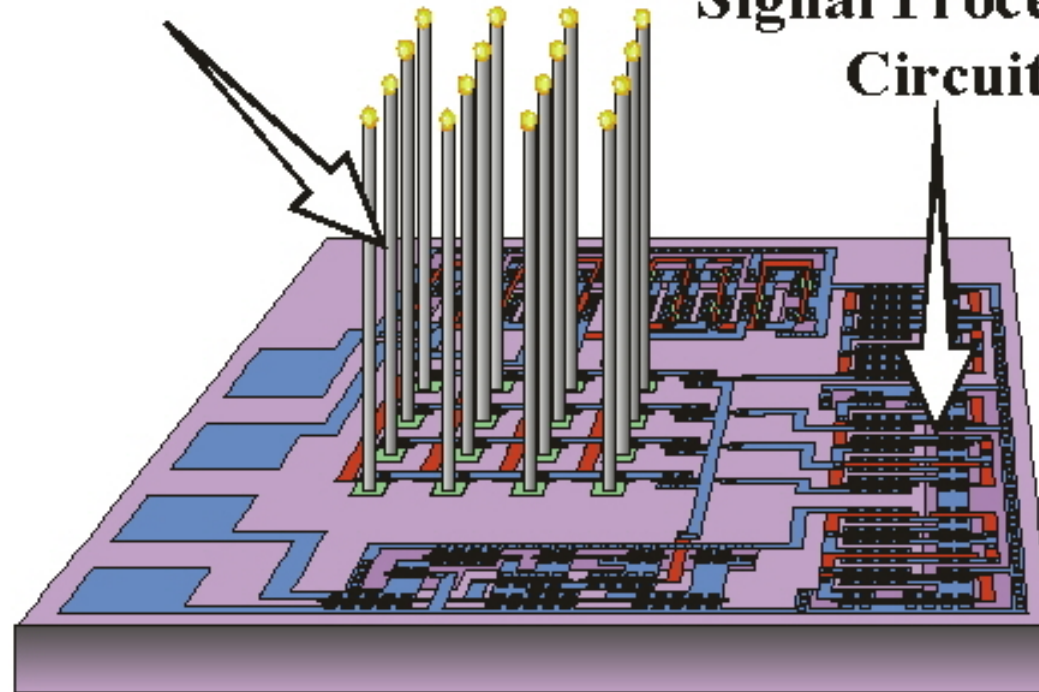

**Makoto Ishida**

*Department of Electrical & Electronic Engineering,  
Toyohashi University of Technology*

# Health and Medicine

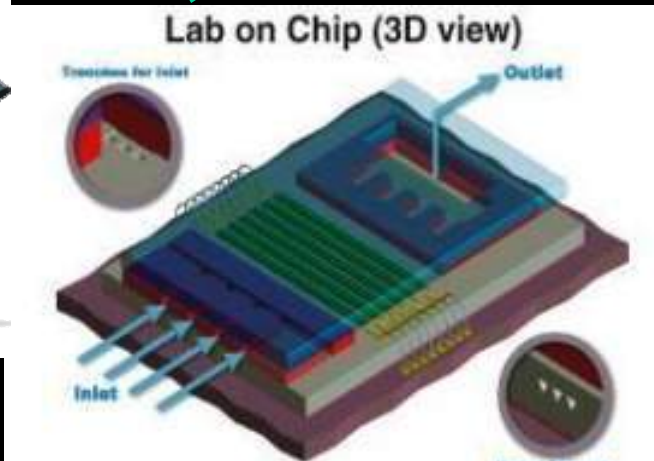
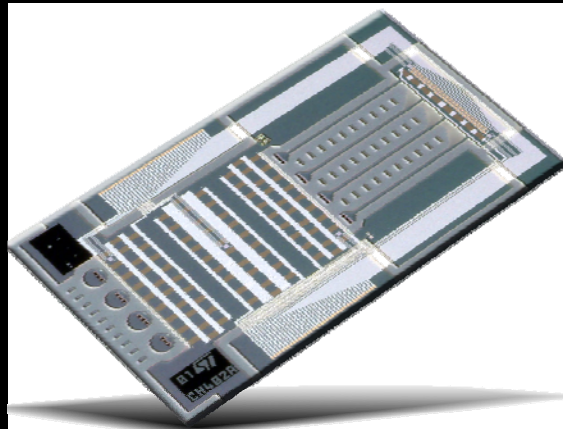

*Pharmaceutical  
lab*

*Lab on chip*

# OUTLINE

- Computing and Data Storage
- Materials and Manufacturing
- Health and Medicine
- **Energy and Environment**
- Transportation
- Security
- Carbon nanotubes, the way to transport electricity

# Energy and Environment

*Two aspects: production and utilization*

- **Energy Production**
  - Clean and low cost
- **Energy Utilization**
  - High efficiency lighting
  - Solid state lighting can reduce total electricity consumption by 10% and cut carbon emission by the equivalent of 28 million tons/year\*



\* Equivalent to 3 times the total power consumption of France



# Lighting



*Ambient intelligence – Philips HomeLab*



# Lighting



# Lighting

*From transparency to opacity*



St Gobain

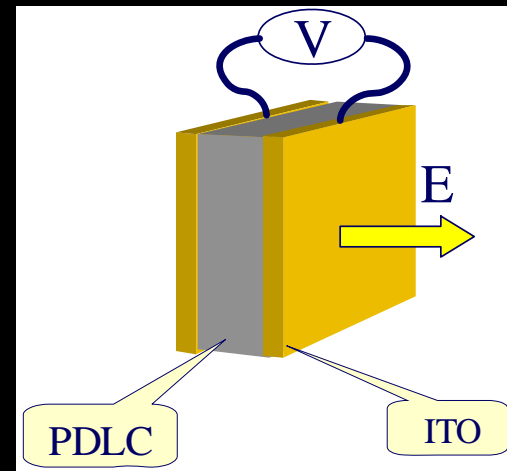
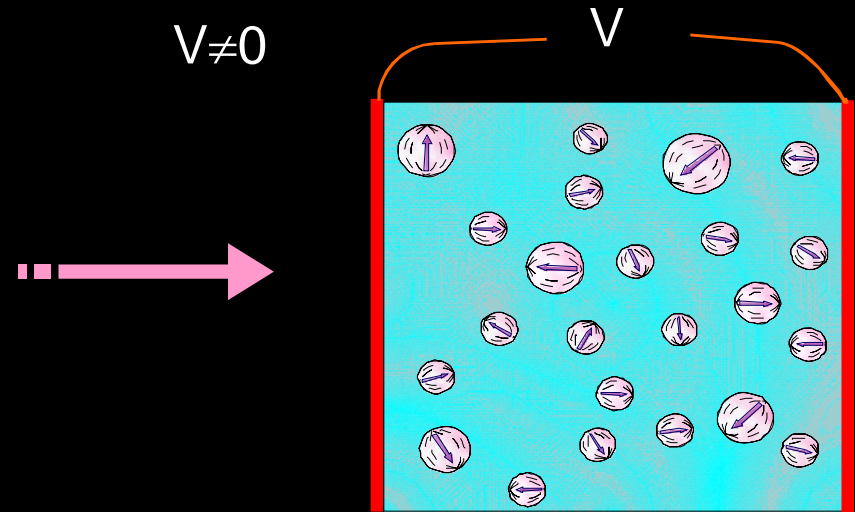

# Energy and Environment

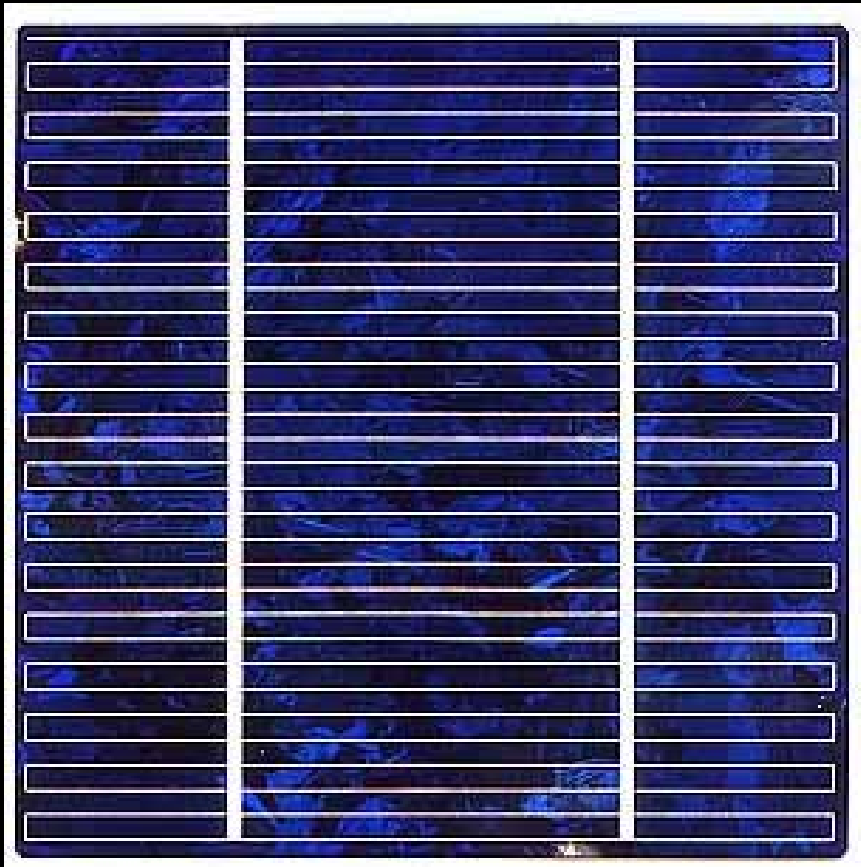

*5 à 28 % Efficiency*



*80 % Efficiency*



# Energy and Environment

## *Reproducing the chlorophyllian synthesis*

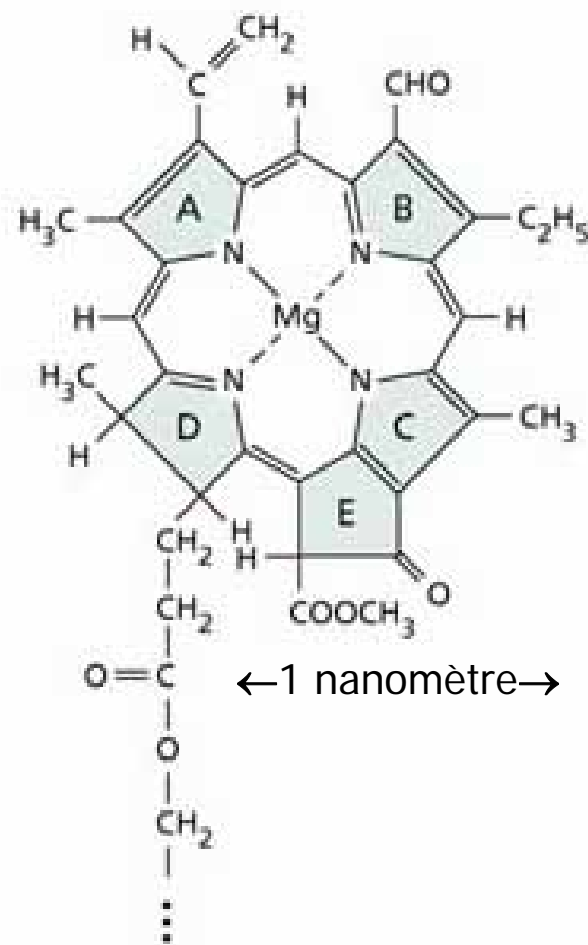
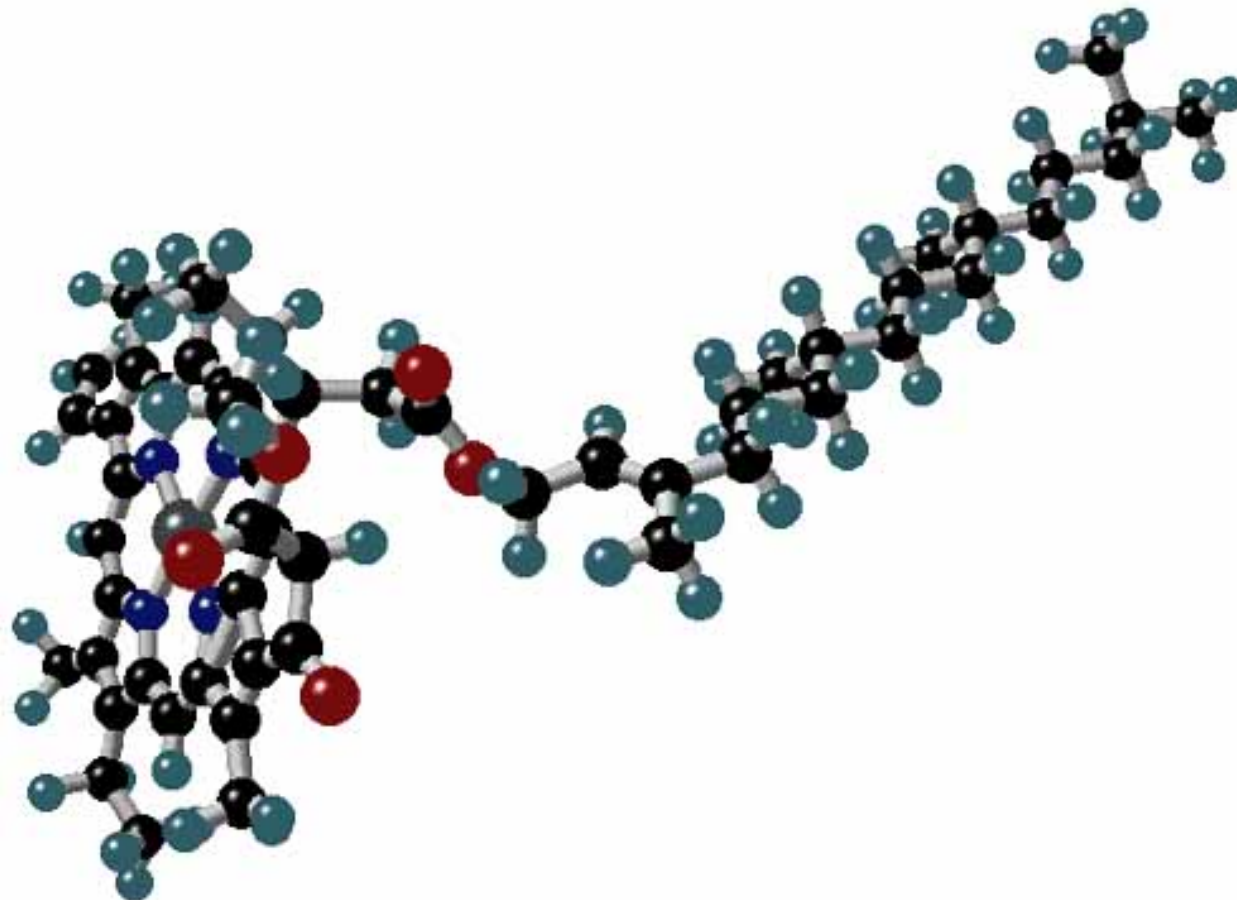

# Energy and Environment

## *Reproducing the chlorophyllian synthesis*

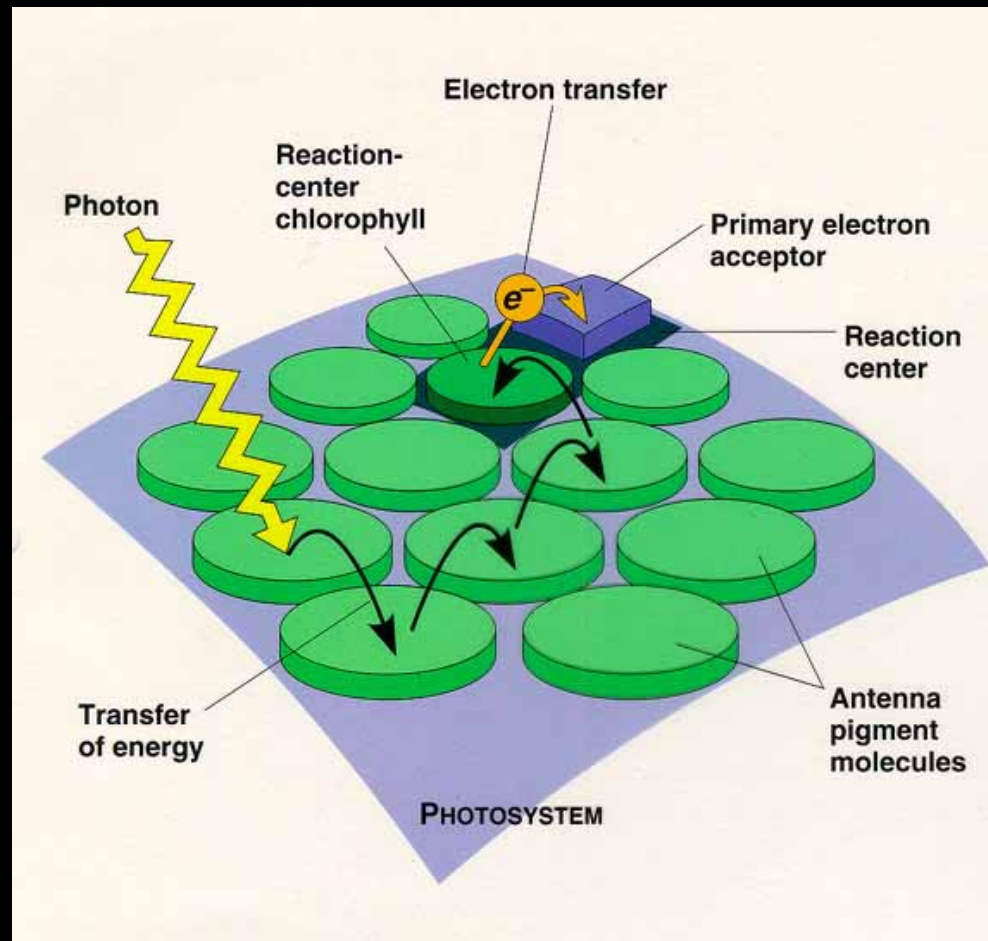



# Energy and Environment

## Solar cells

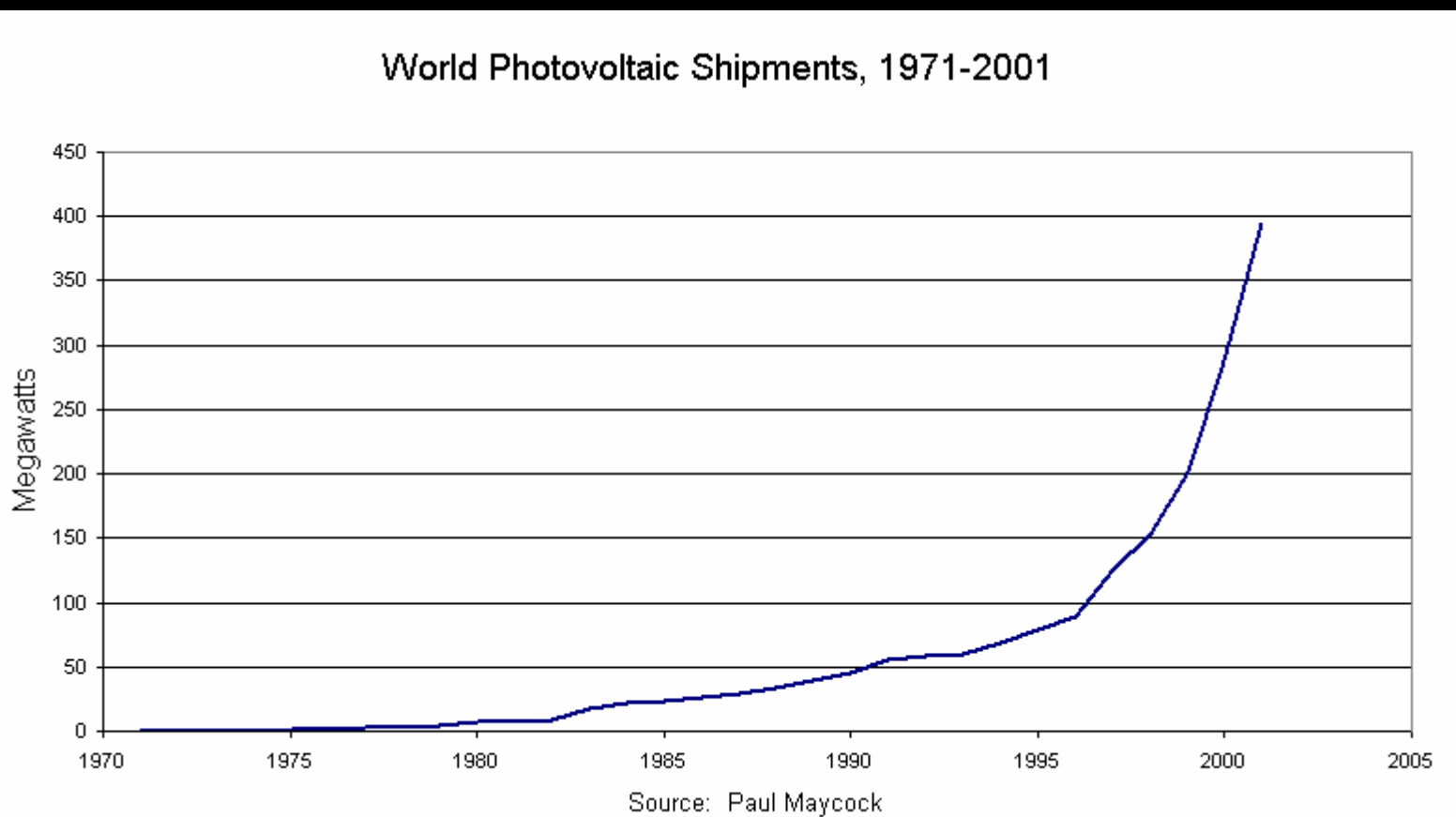

2000 : 400  
MW

2003 : 800  
MW

2006 : 1800  
MW

2001 : 3 G\$

2006 : 10 G\$

2011 : 20-30  
G\$

# OUTLINE

- Computing and Data Storage
- Materials and Manufacturing
- Health and Medicine
- Energy and Environment
- **Transportation**
- Security
- Carbon nanotubes, the way to transport electricity

# Transportation

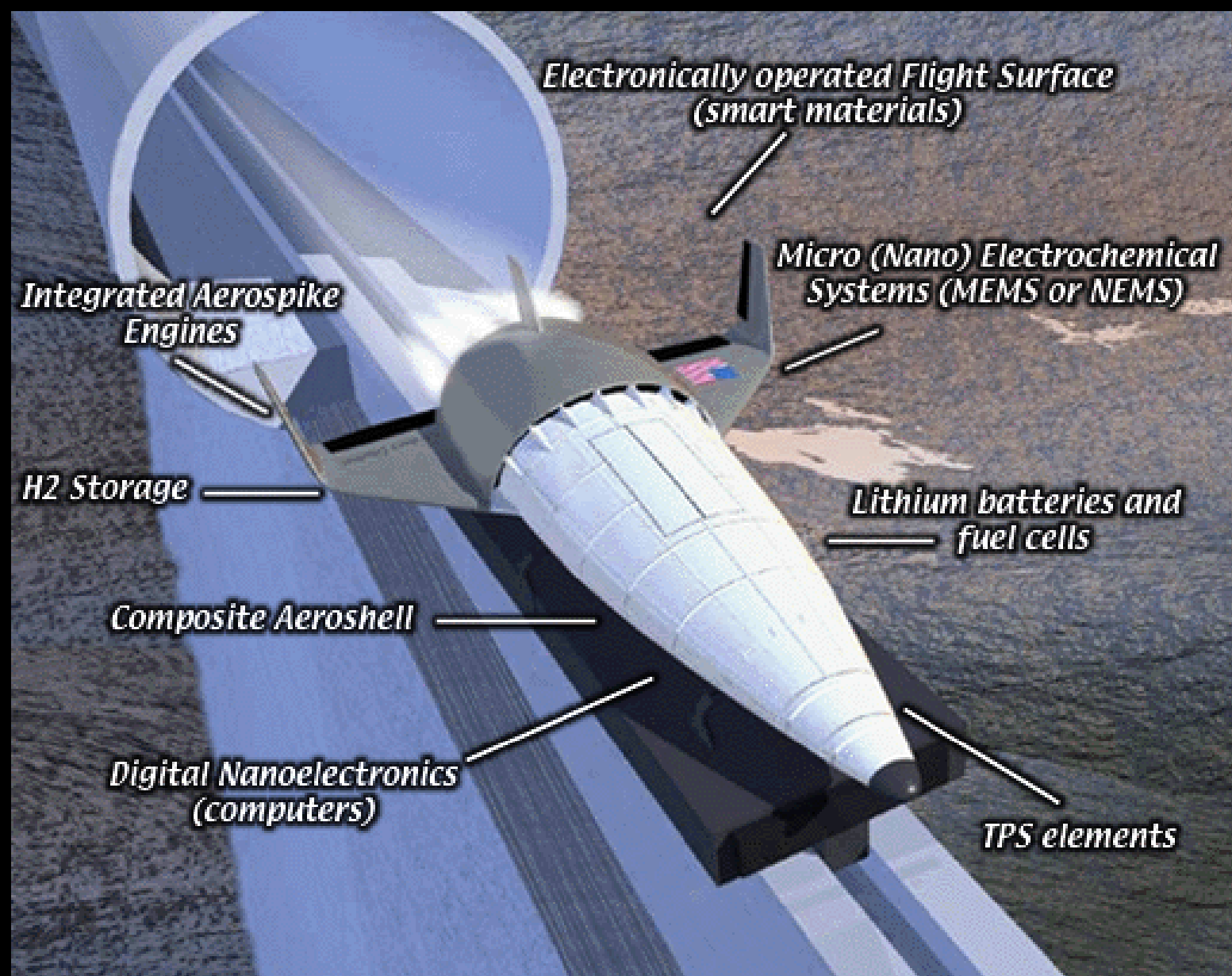

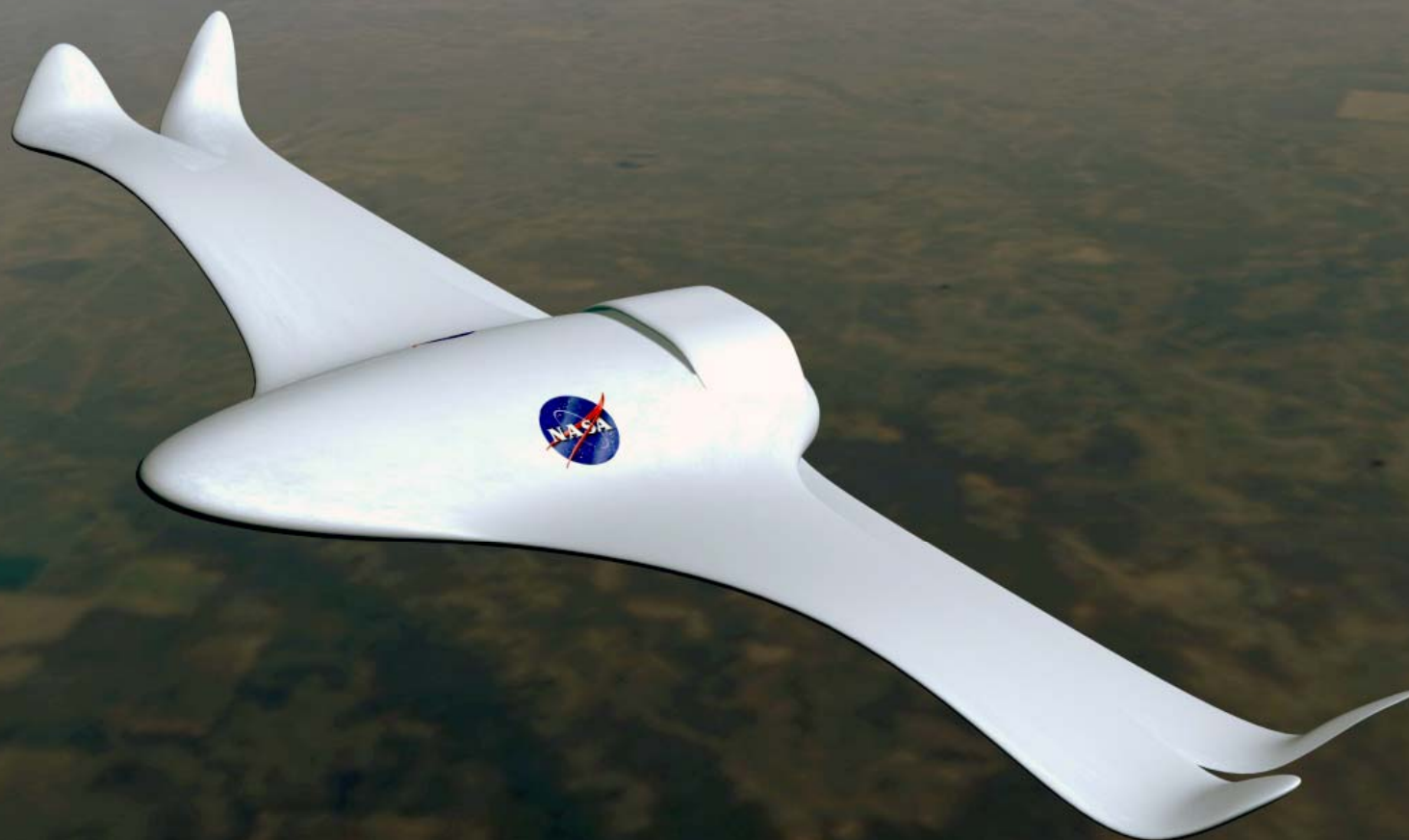

NASA Dryden Flight Research Center Photo Collection

<http://www.dfrc.nasa.gov/gallery/photo/index.html>

NASA Photo: ED01-0348-1 Date: 2001 Photo by: NASA

An artist's rendering of the 21st Century Aerospace Vehicle, sometimes nicknamed the Morphing Airplane, shows advanced concepts NASA envisions for an aircraft of the future.

# Morphing wing

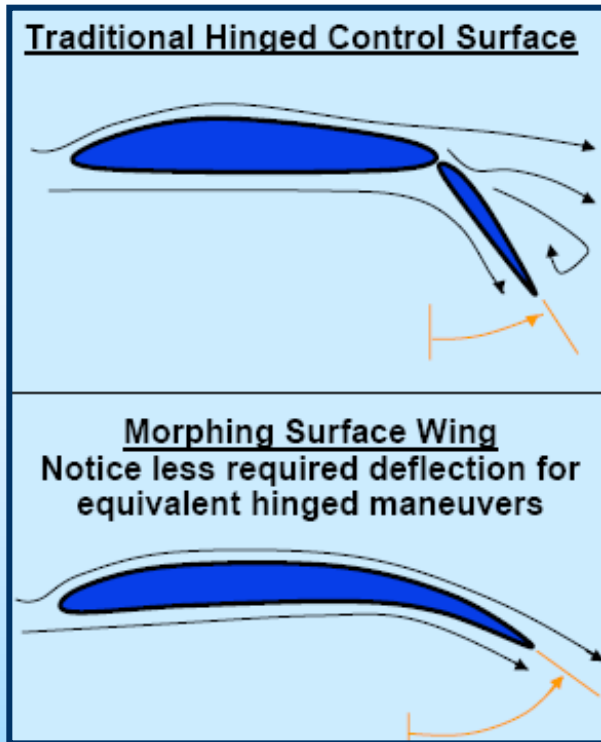

## Designing the 21st Century Aerospace Vehicle

Terry Weisshaar, manager of DARPA' morphing aircraft structure program at the Pentagon



Artist's concept of an adaptive, or "morphing," aerospace vehicle

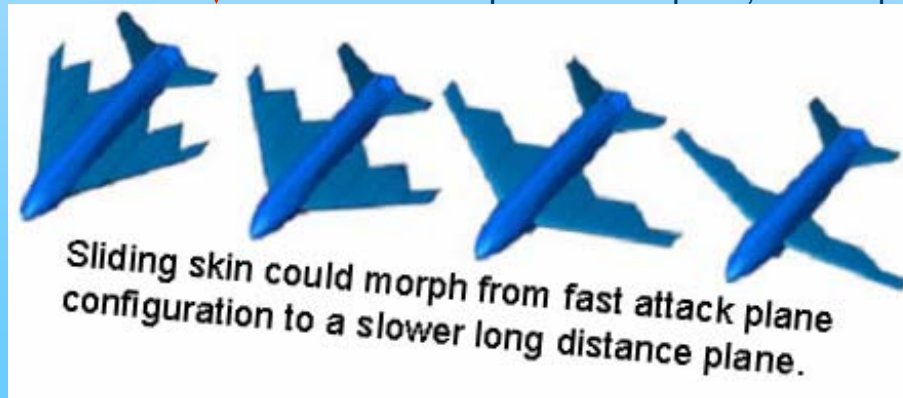

# Space exploration

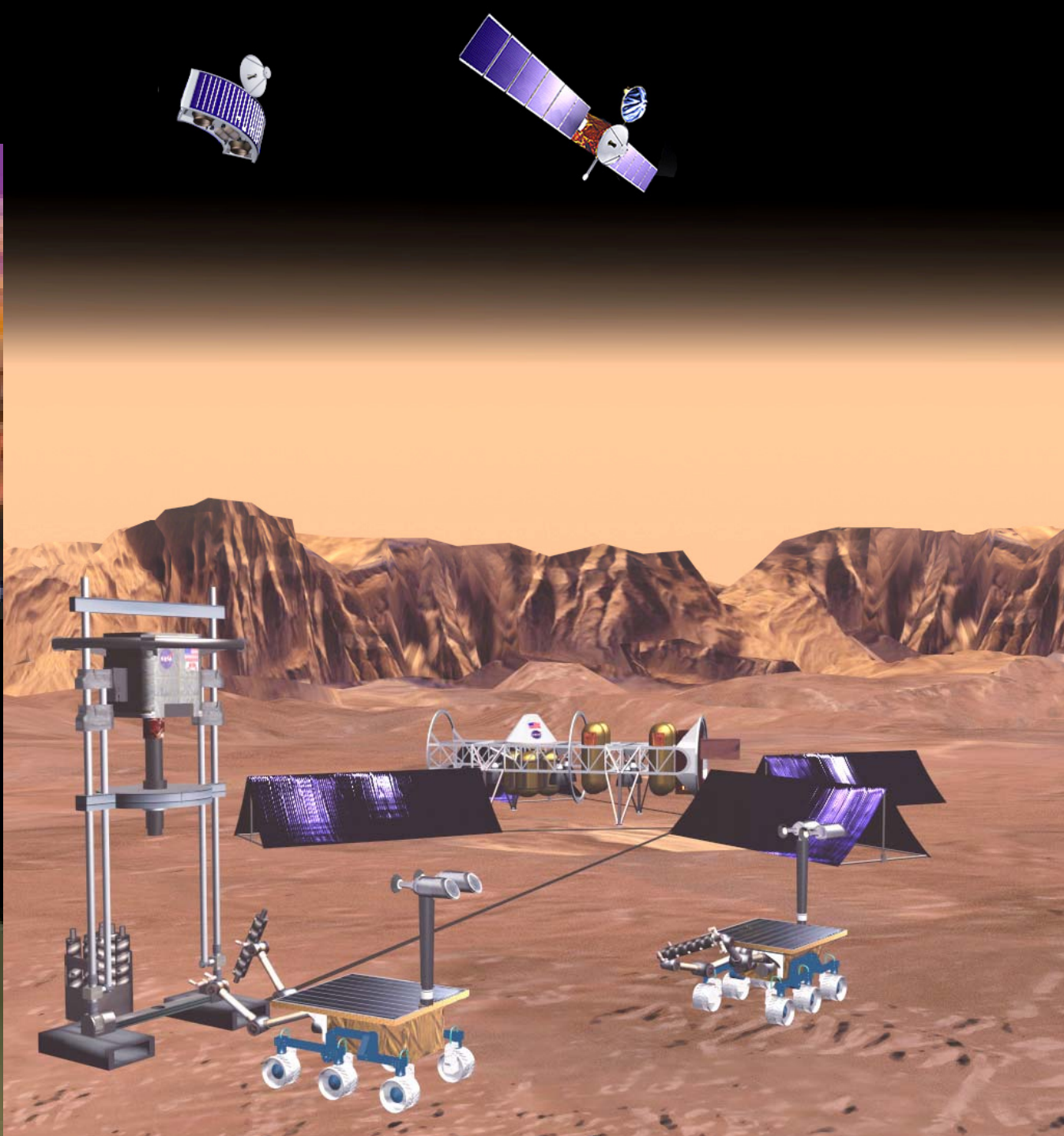



# Transportation / energy

## *Hydrogen storage*

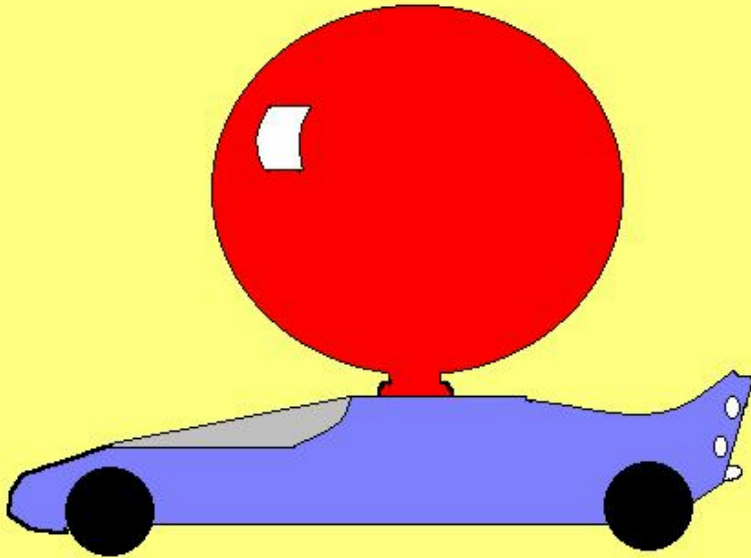

*A hydrogen tank having an energy storage equivalent to a gasoline tank should be 3000 times larger!*

# Transportation

## *Hydrogen storage*

The carbon nanotubes are able to store from 4,2% to 65% of their weight of hydrogen

The density of stored hydrogen can be close to that of liquid hydrogen

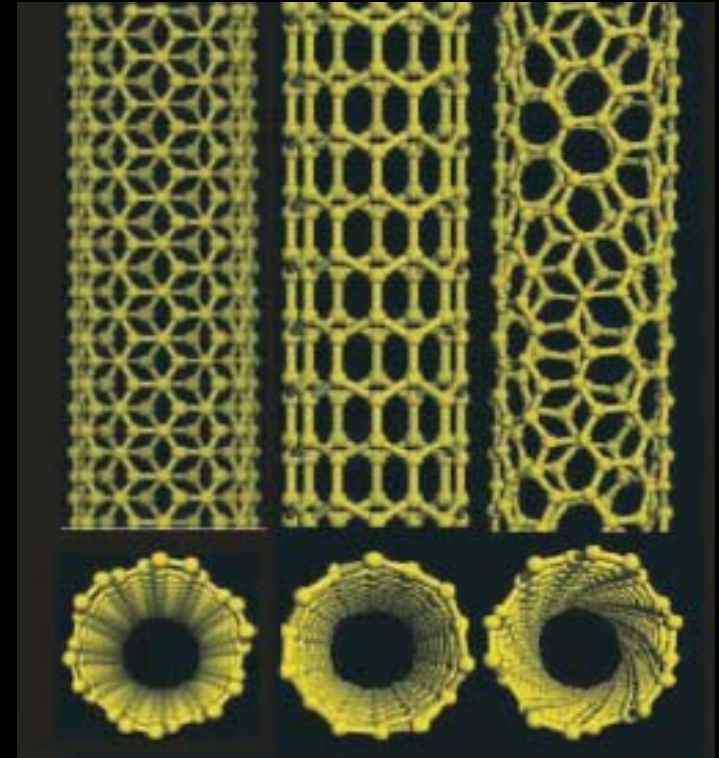

# OUTLINE

- Computing and Data Storage
- Materials and Manufacturing
- Health and Medicine
- Energy and Environment
- Transportation
- **Security**
- Carbon nanotubes, the way to transport electricity

Return to Session

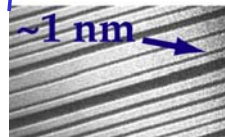
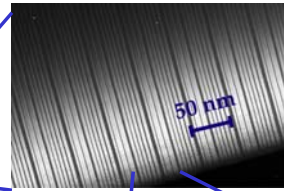
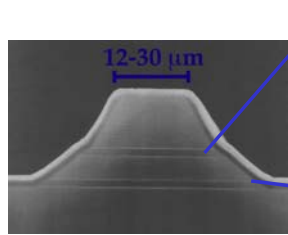
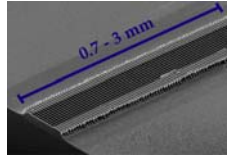
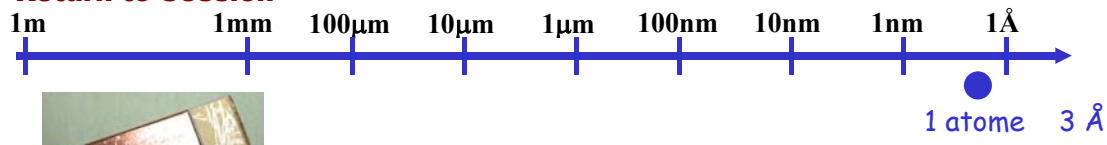

1 cheveu = 50 $\mu$ m  
= 0.00005m

# Quantum Cascade Laser

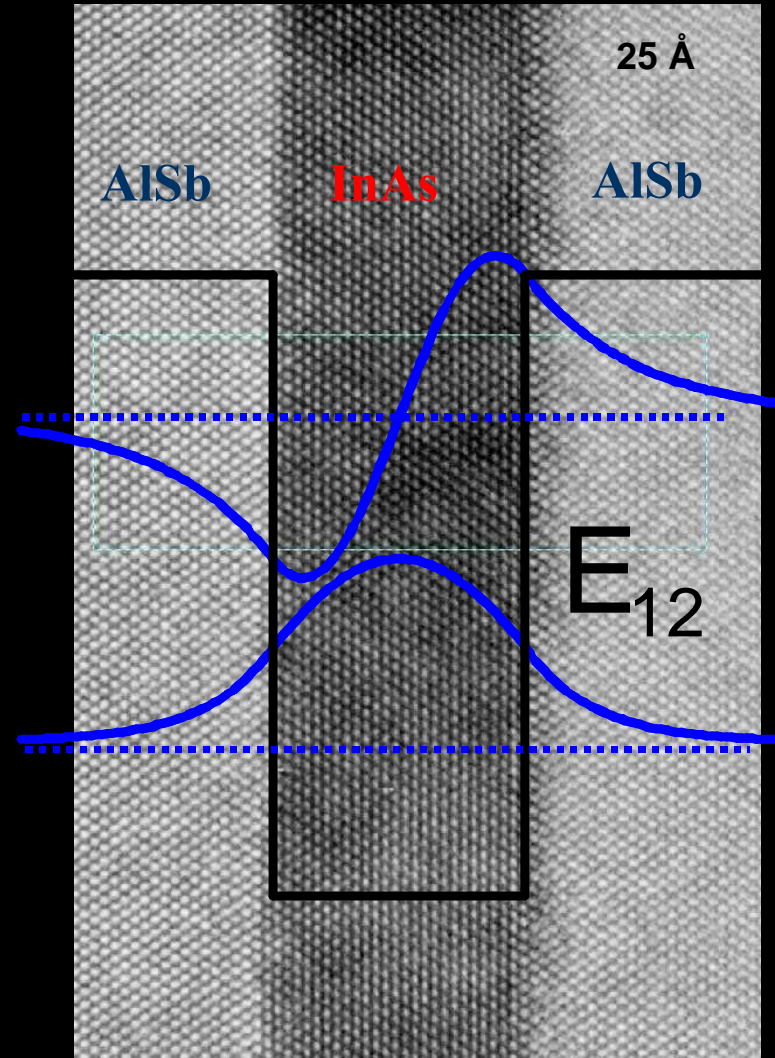
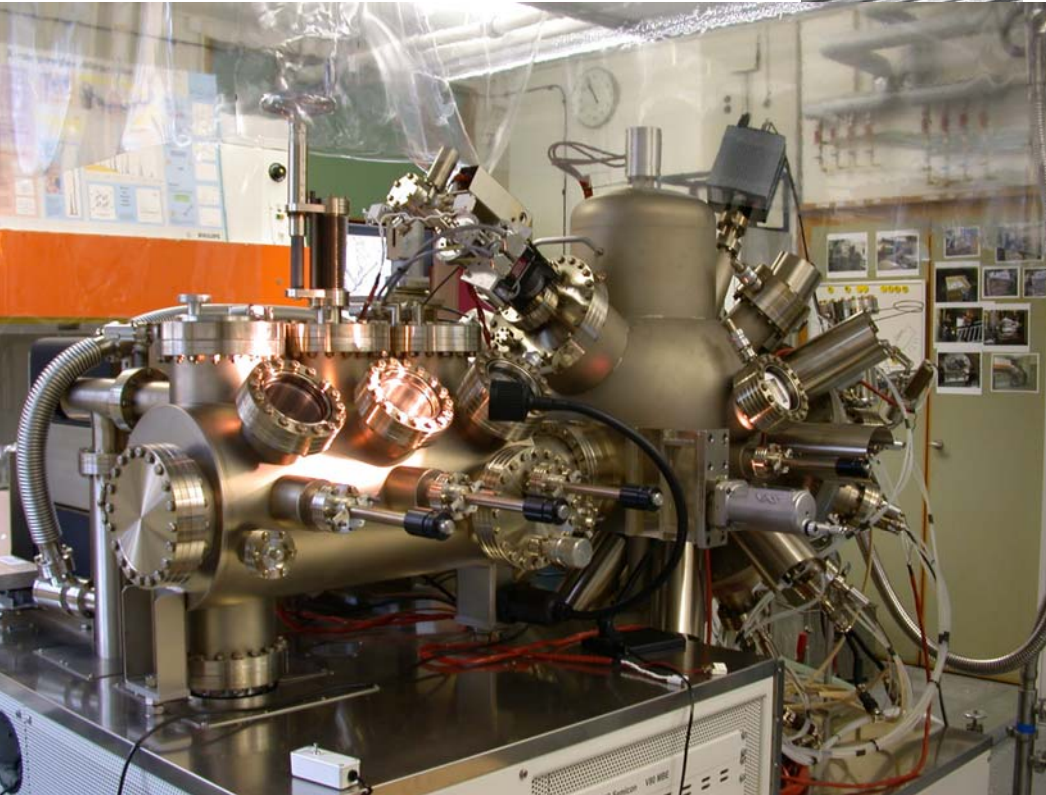



# QC Laser spectrometer operating principle

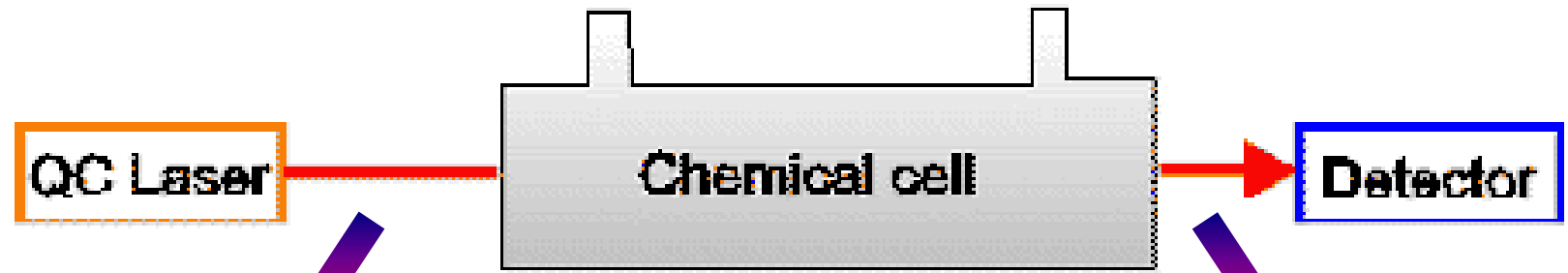

Light Pulse ( $I_0$ )  
Before Sample

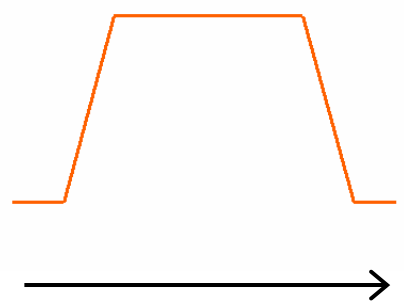

Time (t)

Sample Transmission

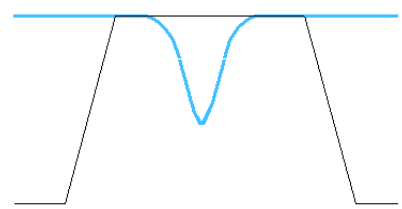

Wavelength ( $\lambda$ )

Light Pulse ( $I_a$ ) After  
Sample

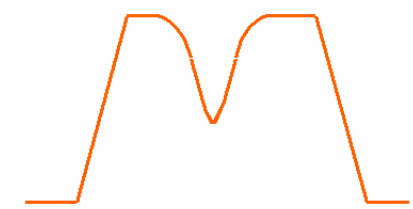

Time (t)

Current pulse  
applied to  
diode contact



Wavelength tuning for pulse  
current duration by  
Instantaneous heating effect



Linear tuning  
to  $\pm 1\%$  for  
200ns

# Security : CNT Transistor for gas detection

Dai et al.

Department of chemistry, Stanford University

### Top view

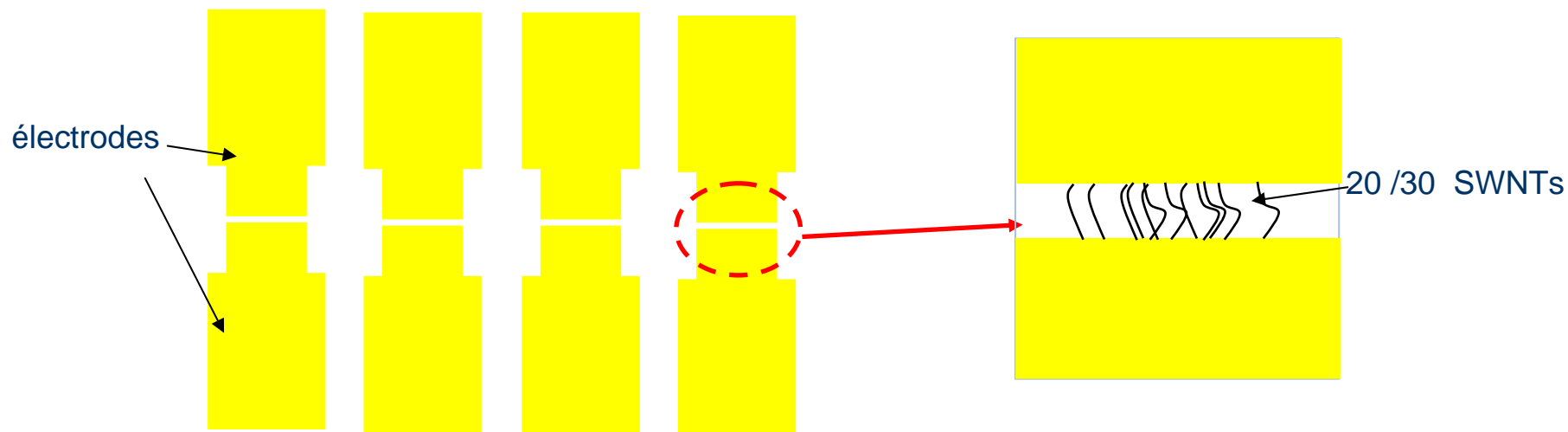

### Bottom view

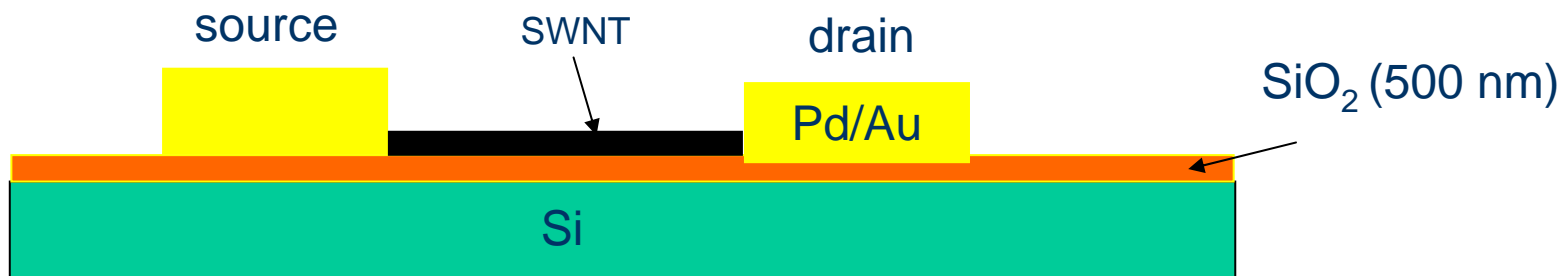



# Security : CNT Transistor for gas detection

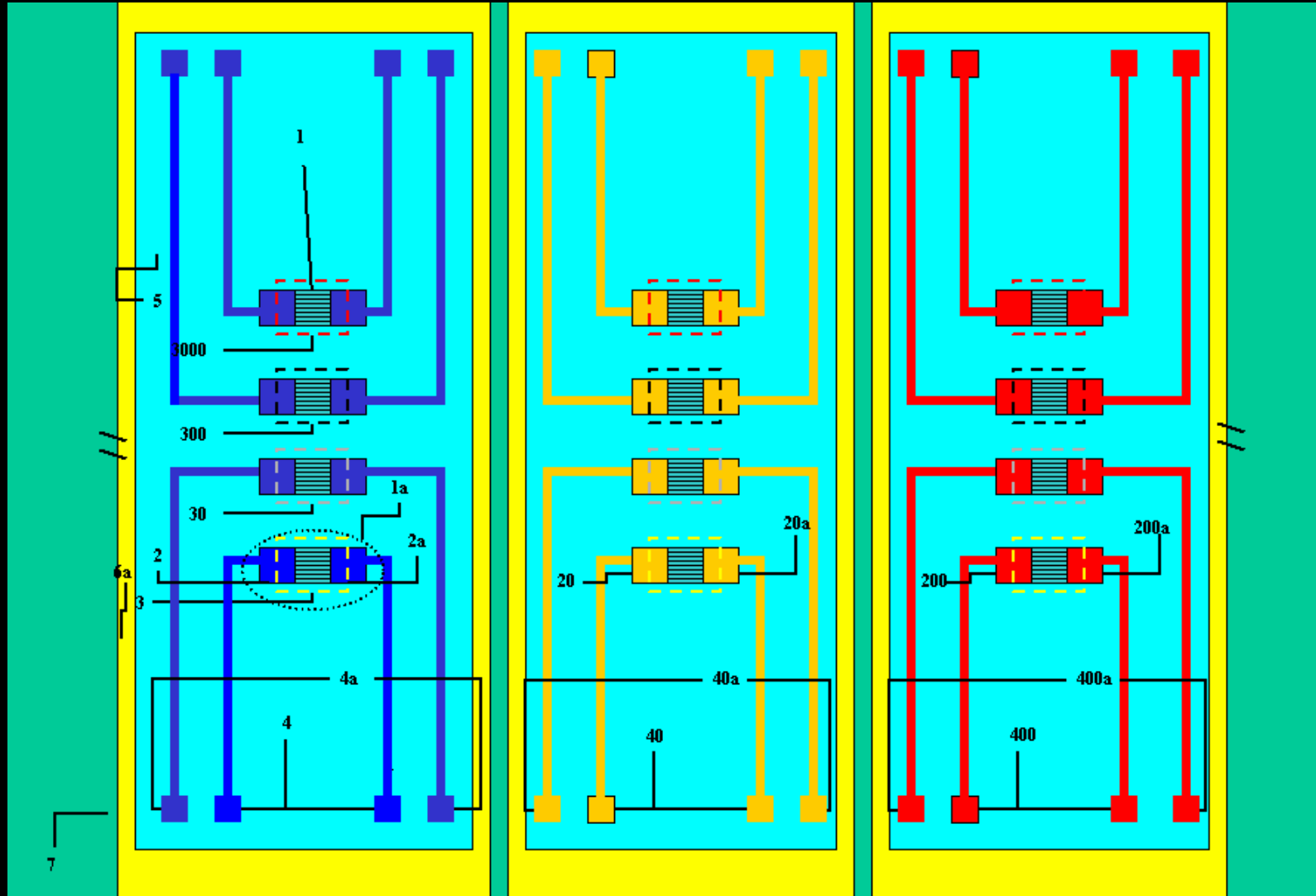

# OUTLINE

- Computing and Data Storage
- Materials and Manufacturing
- Health and Medicine
- Energy and Environment
- Transportation
- Security
- **Carbon nanotubes, the way to transport electricity**

# Carbon nanotube

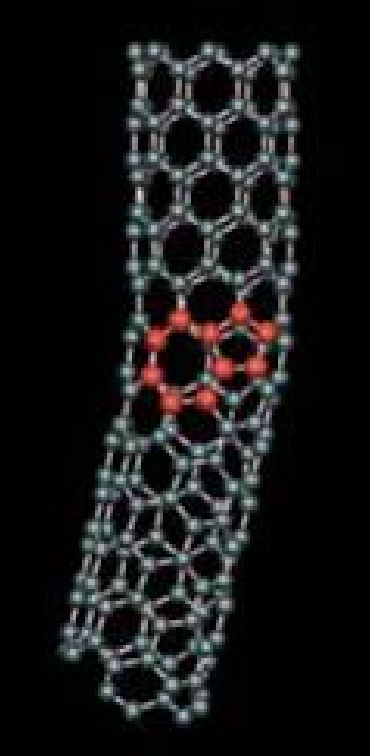
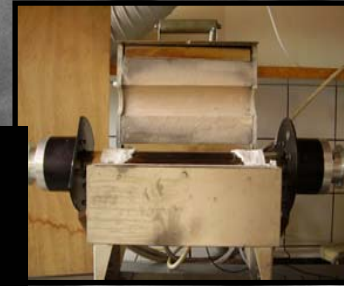
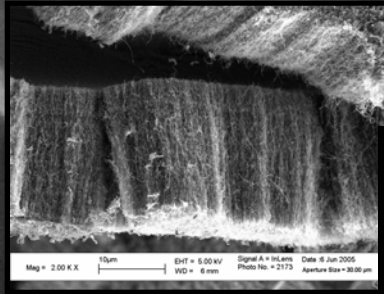

# Single & Multi wall nanotubes

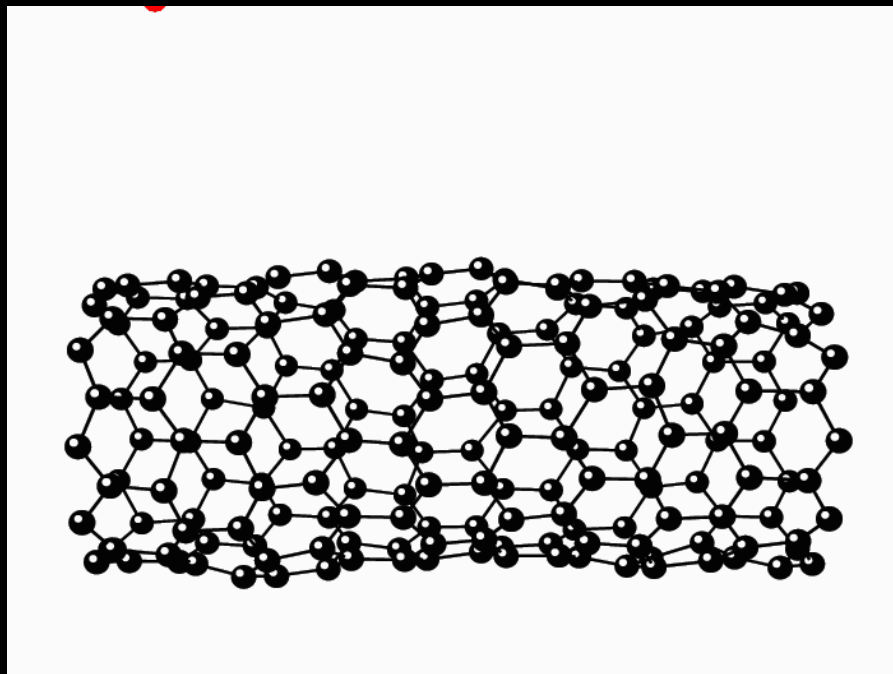

Single wall  
carbon nanotube :  
 $2/3$  SC +  $1/3$  metallic

$\varnothing \sim 1$  nm

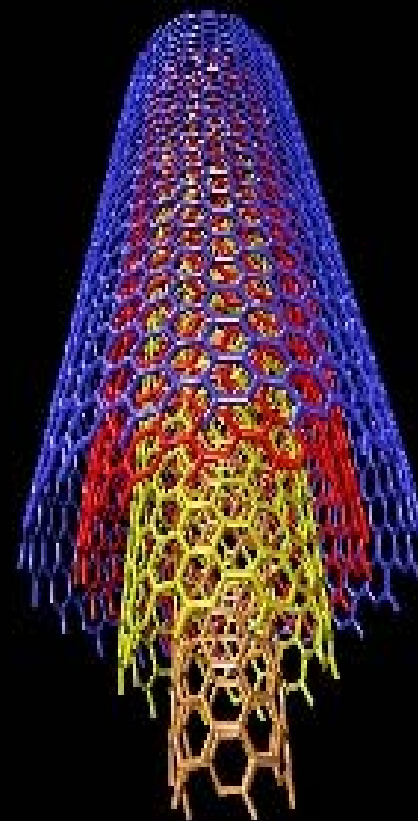

Mutiwall  
carbon nanotube :  
metallic

$\varnothing \sim 20$  nm

# Why Single Wall Carbon Nanotubes?

## MOLECULAR PERFECTION & EXTREME PERFORMANCE



The Strongest Fiber Possible.

Selectable Electrical Properties

Metallic Tubes Better Than Copper

Semiconductors Better Than InSb or GaAs



Thermal Conductivity of Diamond.

The Unique Chemistry of Carbon.

The Scale and Perfection of DNA.



The Ultimately Versatile Engineering Material.

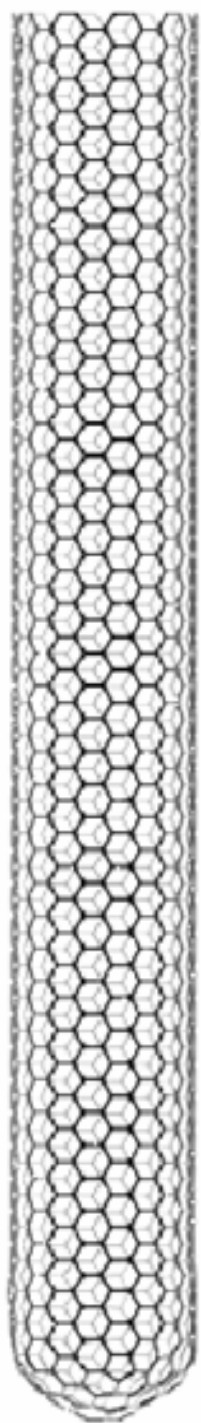
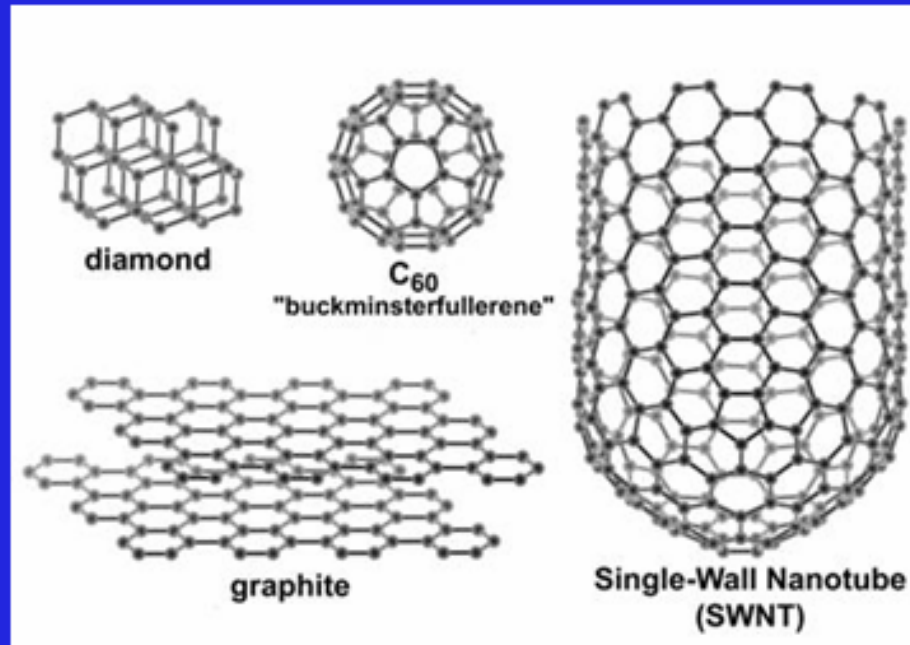
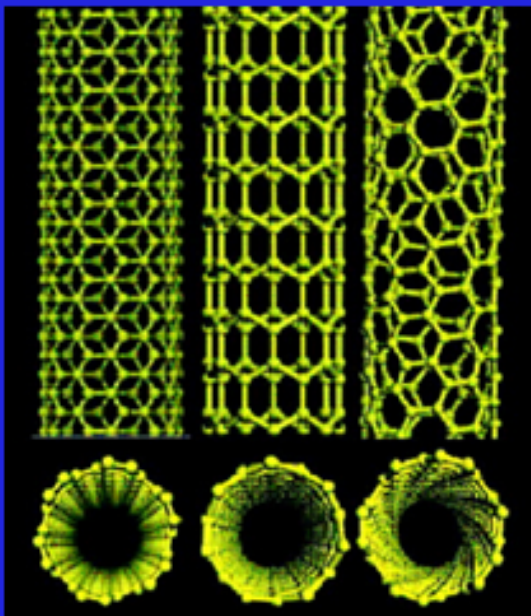



# Electronic properties

- Electric conductivity = twice that of copper
- Able to support great density of current ( $10^9$  A/cm<sup>2</sup>)
- Excellent electronic emissivity (point effect)
- Can be functionalized (chemistry of carbon)
- SWNT can be metallic or semiconductor (depending on the chirality)

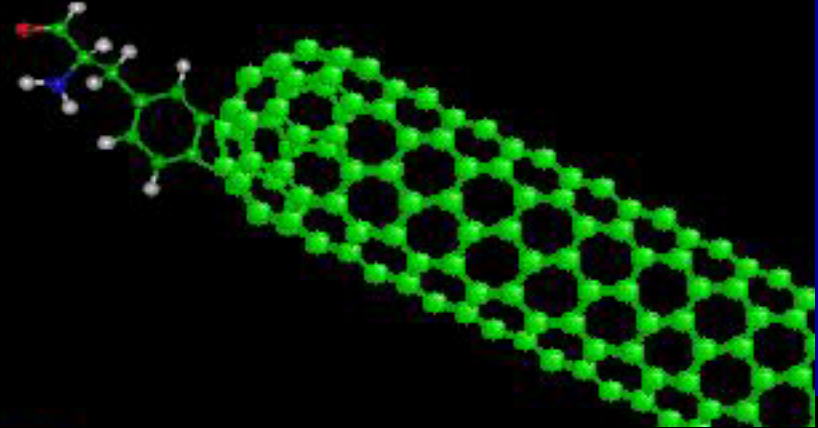



# CNT : the way to transport electricity ?

*Adapted from Richard Smalley*

*I think electric transmission  
is the destiny of this  
material and I want to make  
it happen*

Richard Smalley,  
co-discoverer of fullerene, Nobel  
Prize for Chemistry, 1996

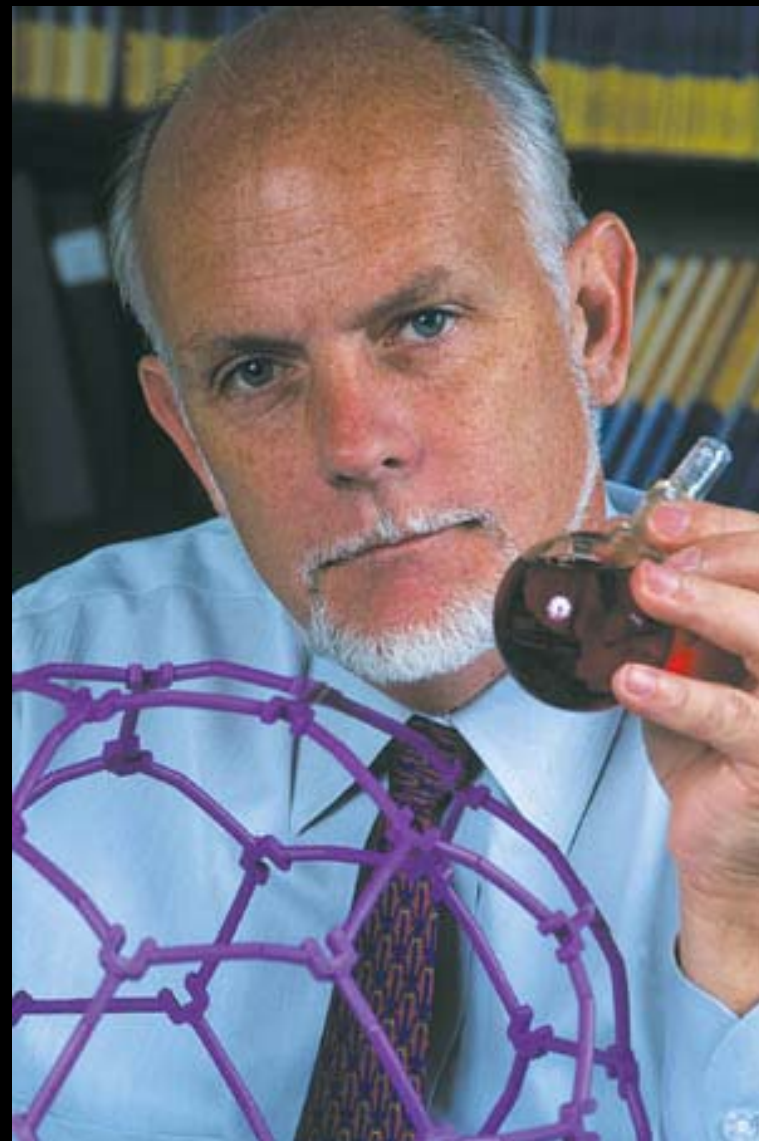

# The ENERGY REVOLUTION (The Terawatt Challenge)

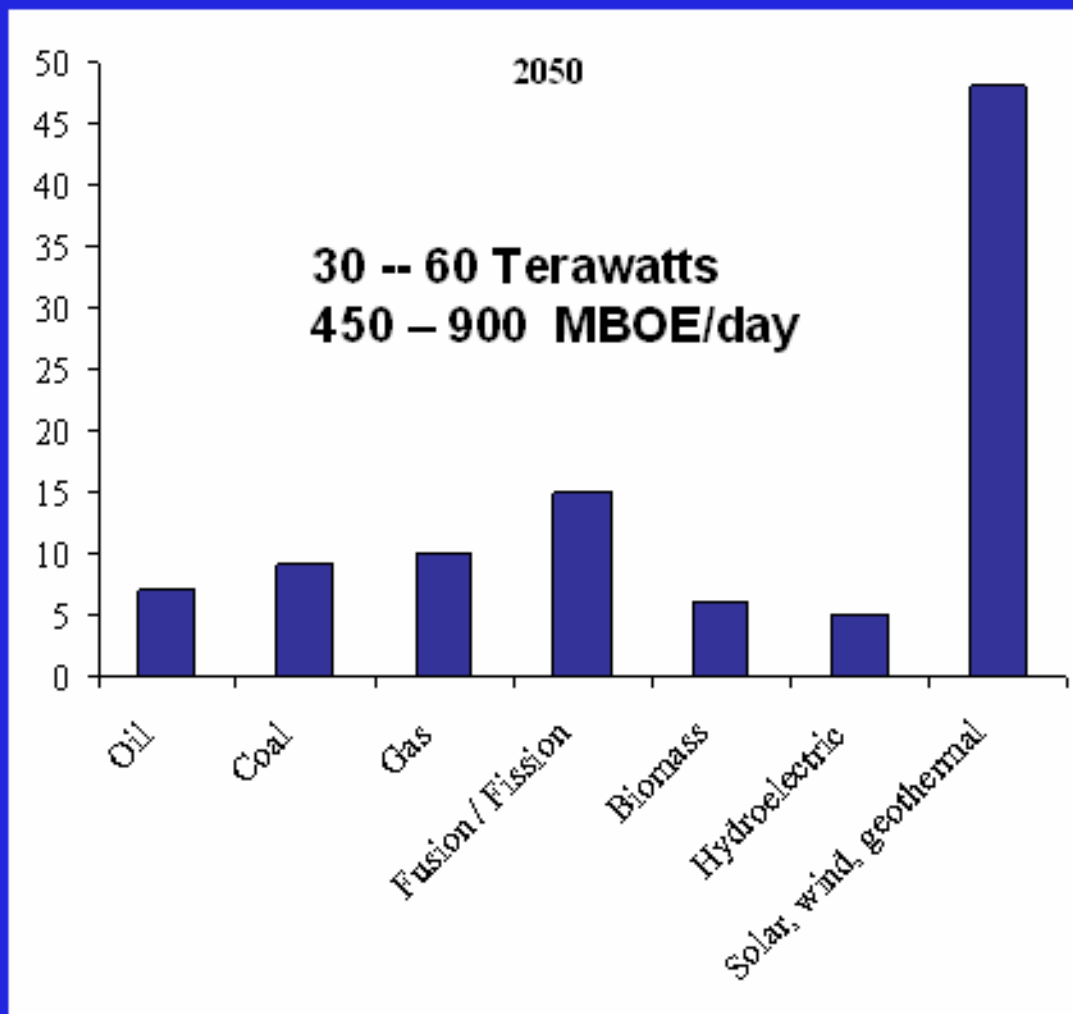
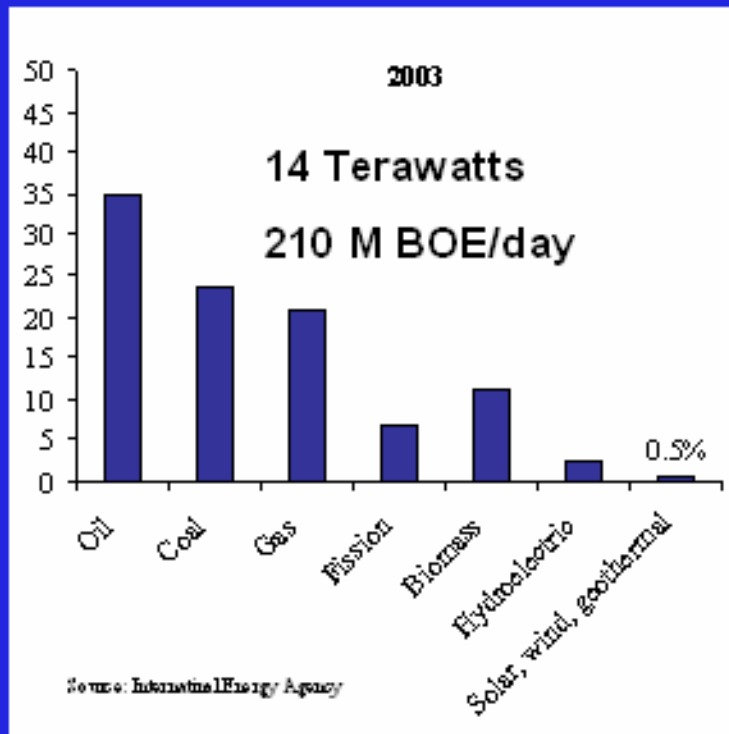

## Energy:

The Basis of Prosperity

20<sup>th</sup> Century = OIL

21<sup>st</sup> Century = ??

# *10 Terawatt minimum for $10^{10}$ people*

165,000 TW  
of sunlight  
hit the earth

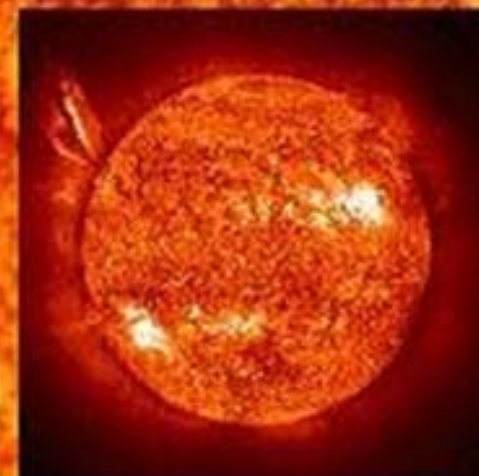
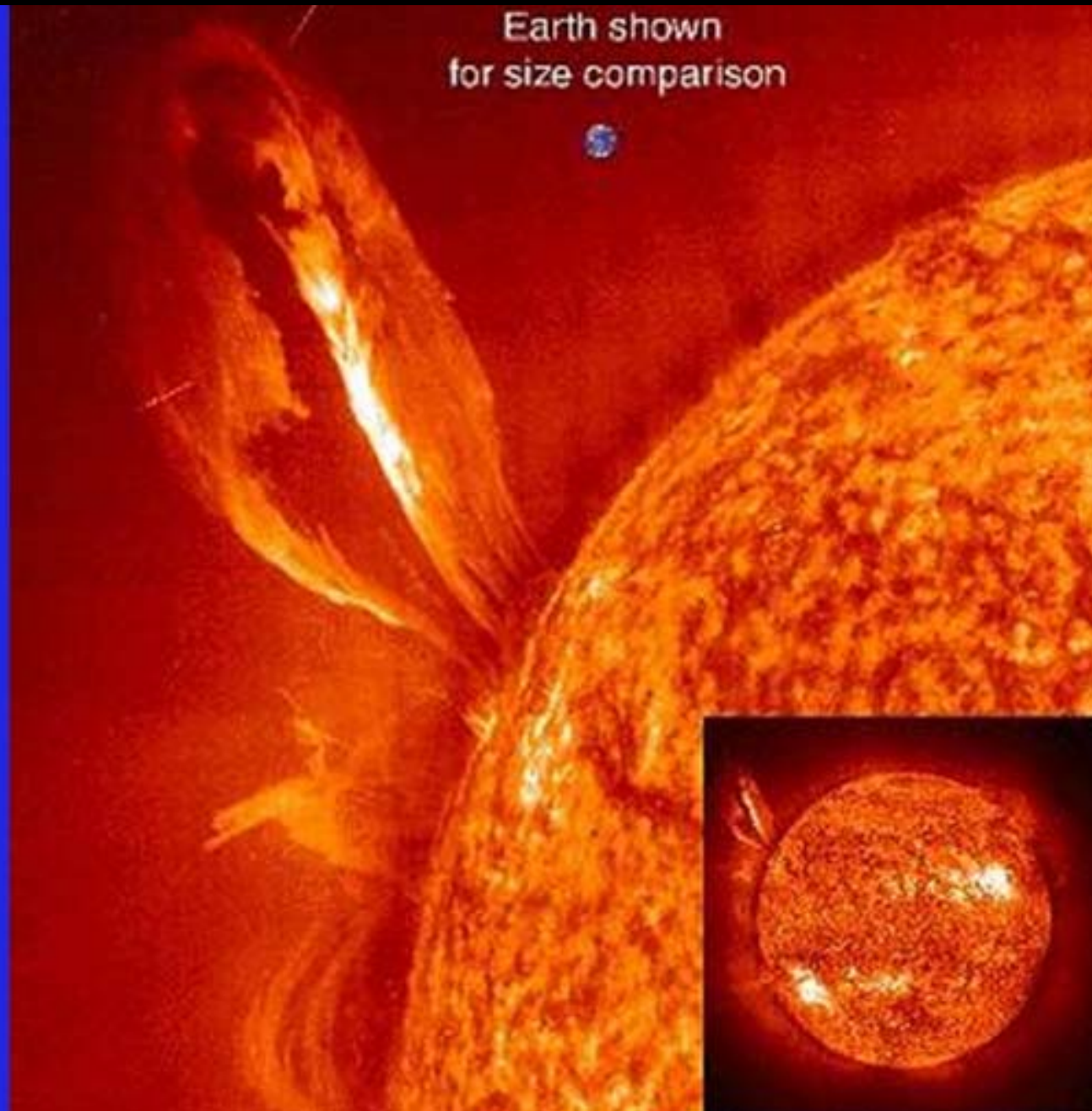



# One World Energy Scheme for 30-60TW in 2050: The Distributed Store-Gen Grid

- Energy transported as **electrical energy** over wire, rather than by transport of mass (coal, oil, gas)
- Vast electrical power grid on continental scale interconnecting ~ 100 million asynchronous "local" storage and generation sites, entire system continually innovated by free enterprise
  - "Local" = house, block, community, business, town, ...
  - **Local storage** = batteries, flywheels, hydrogen, etc.
  - **Local generation** = reverse of local storage + local solar and geo
  - Local "buy low, sell high" to electrical power grid
  - Local optimization of days of storage capacity, quality of local power
  - **Electrical grid does not need to be very reliable, but it will be robust**
  - Mass Primary Power input to grid via HV DC transmission lines from existing plants plus remote (up to 2000 mile) sources on TW scale, including vast solar farms in deserts, wind, NIMBY nuclear, clean coal, stranded gas, wave, hydro, space-based solar... **EVERYBODY PLAYS**
  - **Hydrogen, methanol, ethanol are transportation fuels**
  - Transition technology – Plug-in Hybrids

# Energy Nanotech Grand Challenges

from Meeting at Rice University May 2003  
Report available!

1. **Photovoltaics -- drop cost by 100 fold.**
2. **Photocatalytic reduction of CO<sub>2</sub> to methanol.**
3. **Direct photoconversion of light + water to produce H<sub>2</sub>.**
4. **Fuel cells -- drop the cost by 10-100x + low temp start.**
5. **Batteries and supercapacitors -- improve by 10-100x for automotive and distributed generation applications.**
6. **H<sub>2</sub> storage -- light weight materials for pressure tanks and LH2 vessels, and/or a new light weight, easily reversible hydrogen chemisorption system**
7. **Power cables (superconductors, or quantum conductors) with which to rewire the electrical transmission grid, and enable continental, and even worldwide electrical energy transport; and also to replace aluminum and copper wires essentially everywhere -- particularly in the windings of electric motors and generators (especially good if we can eliminate eddy current losses).**

# SWNT Quantum Wire

## Expected Features

- 1-10x Copper Conductivity
- 6x Less Mass
- Stronger Than Steel
- Zero Thermal Expansion

## Key Grid Benefits

- Reduced Power Loss
- Low-to-No Sag
- Reduced Mass
- Higher Power Density

## SWNT Technology Benefits

- Type & Class Specific
- Higher Purity
- Lower Cost
- Polymer Dispersible

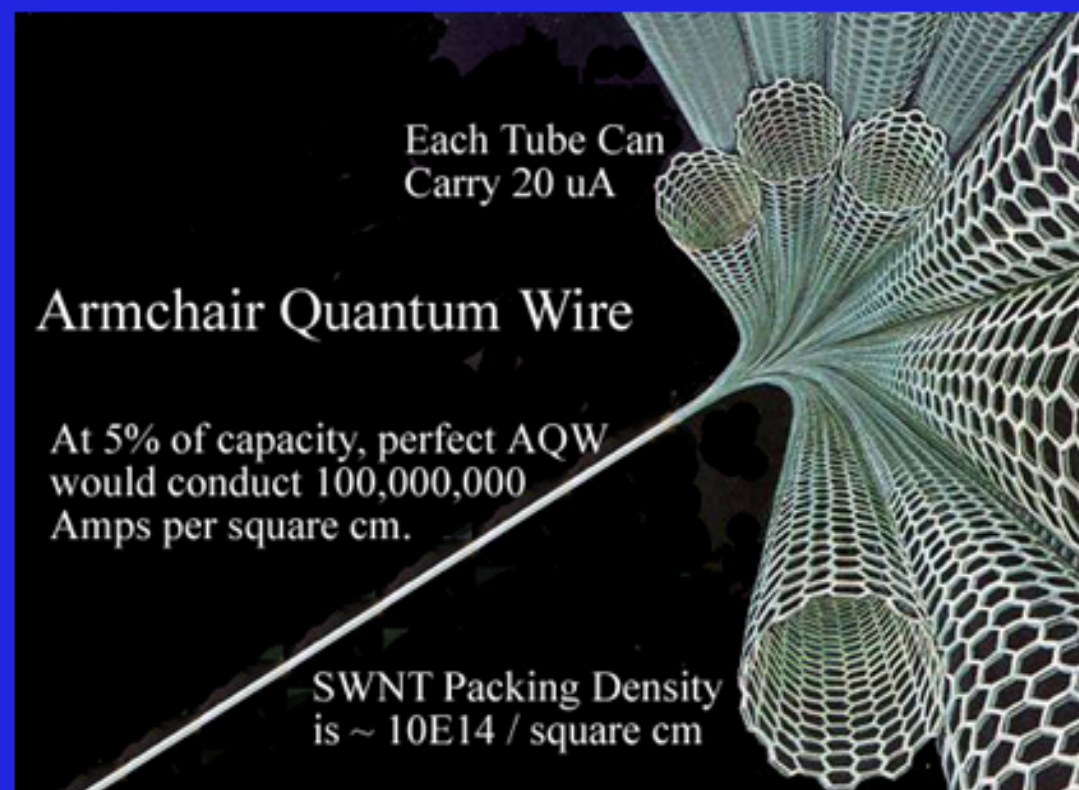

Each Tube Can  
Carry 20 uA

## Armchair Quantum Wire

At 5% of capacity, perfect AQW  
would conduct 100,000,000  
Amps per square cm.

SWNT Packing Density  
is  $\sim 10E14$  / square cm



# Production Scale-Up Path

- Rice made 1 mg / day in 1997
- Lab-scale reactor at 1 gm / hour (2002)
- CNI Pilot plant producing 20 lb /day
- CNI now testing 100 lb / day reactor



# Estimated future global production of nanotubes

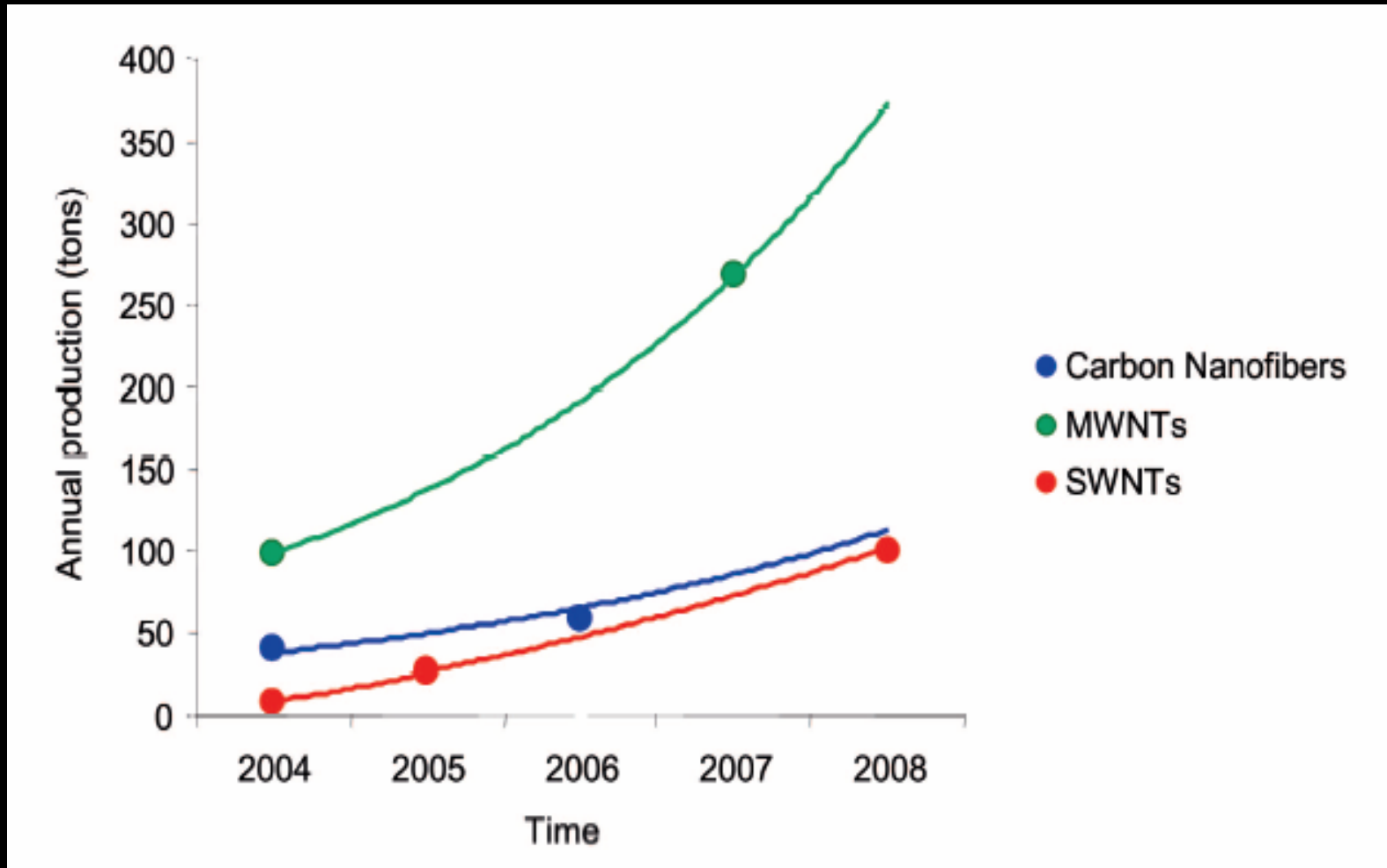

# Prototype Wire - SWNT Fibers

- Producing Neat SWNT Fibers
- Dry-Spun from Oleum
- 6 to 14 Wt. % SWNT Dope
- Extruded as 50  $\mu\text{m}$  Dia. Fibers
- $10^9$  Tubes in Cross Section
- 100 Meters Long

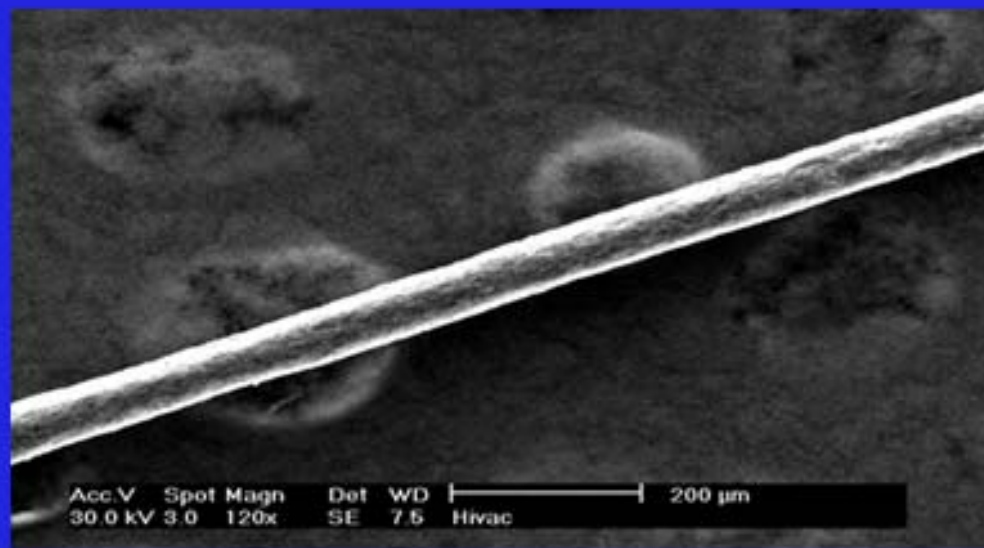

**Science 305, 1447-1450, 3 September 2004!!!**



# Quantum Wire on The Grid

## Key Grid Benefits

- Eliminate Thermal Failures
- Reduce Wasted Power
- Reduce Urban R.O.W. Costs
- Enable Remote Generation

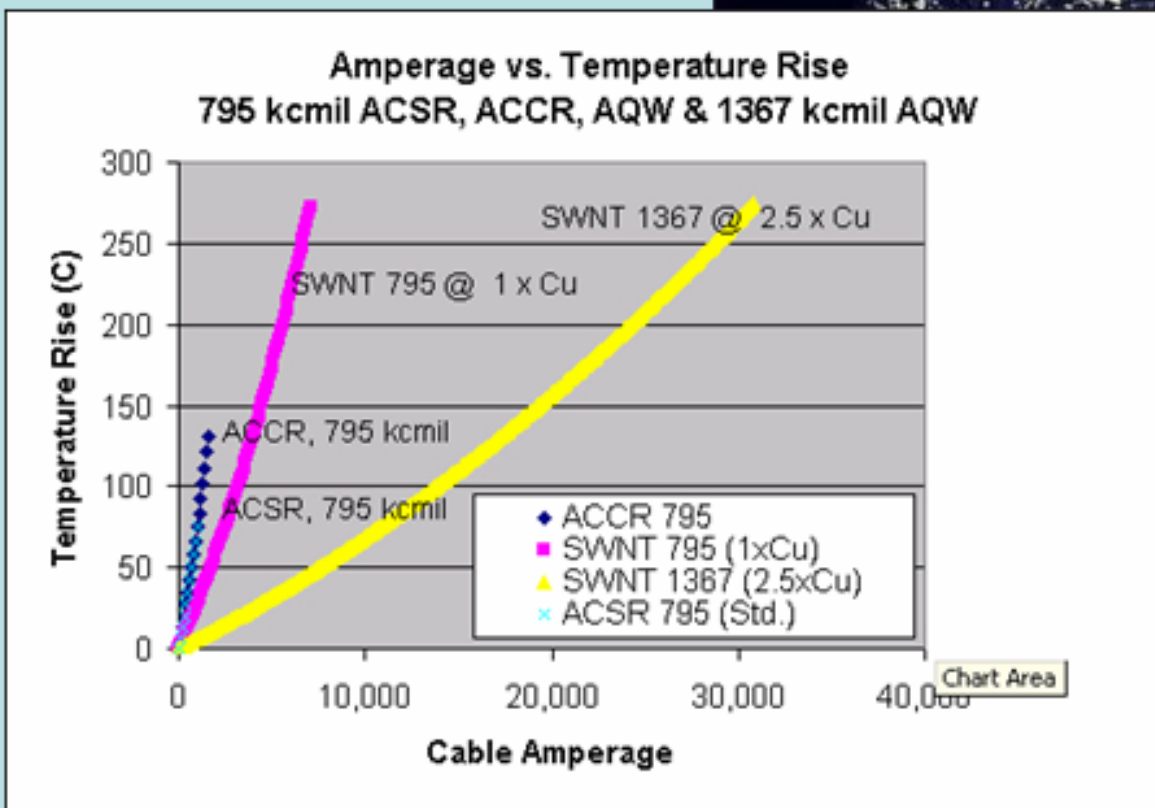
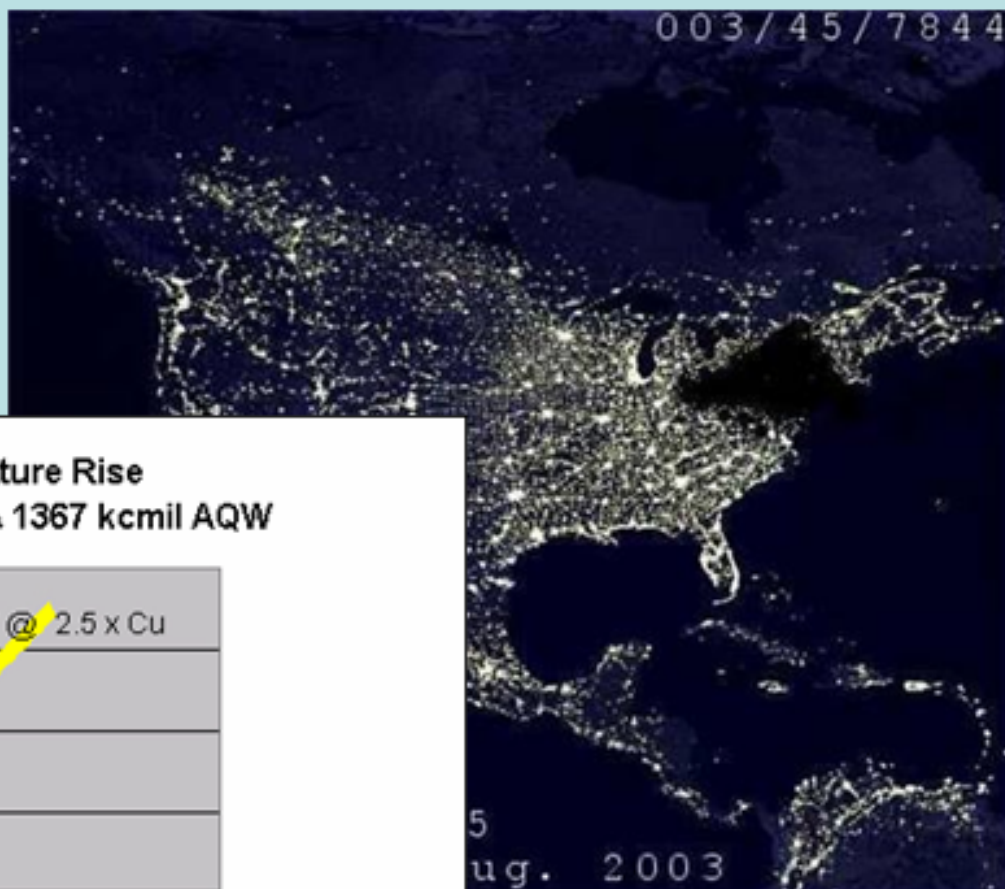

# Grid Applications & Benefits

- Eliminate Thermal-Sag Failure: Now a \$100B+ a year problem.
- Short-Distance AC: AQW<sup>\*</sup> could increase throughput up to ten-fold without increasing losses while using only existing towers and rights-of-way. Avoid new construction in congested urban areas – estimated over \$100M per mile.
- Medium-Distance AC: AQW<sup>\*</sup> could decrease resistive losses and voltage drop ten-fold if amperage were not increased. This would improve grid dynamics significantly in the range between 100 and 300 miles, where voltage stability limits deliverable power.
- Long-Distance HVDC: AQW<sup>\*</sup> could permit amperage throughput ten fold or reduce losses ten-fold. New conventional lines cost \$1M to \$2M per mile, plus about \$250M per AC/DC converter station.
- Remote Power: Could enable utilization of large-scale renewables and remote nuclear.

# Conclusions

- The control of the matter produced, at the end of the 18th century, a first technological and industrial revolution
- In the middle of the 20th century, the control of the matter on a micrometer scale was at the origin of a second technological revolution, which was concretized by the development of micro electronics
- It is probable that the nanosciences and the nanotechnologies, will constitute, during the 21st century, the third technological and industrial revolution



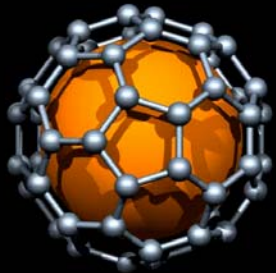

*The End*

**Thank you for your attention**

