

MEDIUM VOLTAGE SUPERCONDUCTING CABLE SYSTEMS FOR INNER CITY POWER SUPPLY

Mark **STEMMLE**, Frank **SCHMIDT**, Nexans Deutschland GmbH, (Germany), mark.stemmle@nexans.com, frank.schmidt@nexans.com

Achim **HOBL**, Nexans Superconductors GmbH, (Germany), achim.hobl@nexans.com

Frank **MERSCHEL**, RWE Deutschland AG, (Germany), frank.merschel@rwe.com

Mathias **NOE**, Karlsruhe Institute of Technology, (Germany), mathias.noe@kit.edu

ABSTRACT

This paper presents the results of a study comparing inner city power supply options including High Temperature Superconducting power cables within a typical urban area power system. A complete new grid concept, which only becomes feasible through the use of superconductor cables, is shown. The different options including conventional high voltage and medium voltage cables as well as medium voltage superconducting cables are compared regarding their technical and economical properties.

KEYWORDS

Superconductivity; HTS cables; medium voltage superconductor cables; inner city power supply.

INTRODUCTION

In Germany and also other European countries the power supply within cities is predominantly ensured through high, medium and low voltage power cables. Many of these cables as well as associated substations are approaching the end of their lifetime and therefore need to be refurbished in the short and medium term. Typically, old power devices will be simply replaced by new ones, and if there are major load changes substations will be adapted accordingly by up- or downgrading.

Employing high temperature superconducting (HTS) power cables as replacement for conventional cables could be an interesting option. For a few years now, several superconductor cables have been tested in real grid applications worldwide [1,2,3]. The experience gathered in these tests shows, that all technical requirements are fulfilled so far, and a high reliability can be assured. Overall, HTS cables are on the verge of commercialization, which however will essentially depend on the price development for the HTS material as well as further technological developments.

This paper is based on a study conducted by the Karlsruhe Institute of Technology on behalf of the German utility RWE [4]. Together with superconductor cable specialists from Nexans as well as other partners, it was investigated whether the electric power supply with

medium voltage superconductor cables in city centers offers technical and economical advantages compared to conventional high voltage technology.

URBAN AREA GRID CONCEPTS

The German city of Essen, which is situated within RWEs supply area, was chosen as example for the study. Based on RWEs load forecast for the year 2020 and already existing high voltage (HV) to medium voltage (MV) substations the concept for the grid with conventional technologies is shown in figure 1. In this concept ten major substations are located within the urban area of Essen, each equipped with two 40 MVA, 110/10 kV transformers. The connection of the substations is mostly realized with 110 kV underground cables (UGC), and a few overhead line (OHL) links. The electrical parameters for the links are provided in table 1. Through balancing the total system load equally between substations a maximum load of 40 MVA with a power factor of 0.9 lagging is achieved for each substation.

Further, the surrounding grid is represented through the generation infeed in the substations B, G and J. With respect to the grid structure G is identified as slack bus whereas B and J are generator busses with an infeed of 140 MW and 100 MW at the maximum system load. In order to keep short circuit currents in the 10 kV system at an acceptable level the 10 kV busses are divided within each substation. In the system, all substations comply with the n-1 criterion with respect to transformer capacity and also with respect to the 110 kV links connecting each substation. Through introducing medium voltage cables, especially HTS cables, for connecting 10 kV busses of different substations, a new grid concept becomes feasible.

	110 kV UGC (conventional)	110 kV OHL (conventional)	10 kV UGC (conventional)	10 kV UGC (HTS)
Type	N2XS(FL)2Y RM/35 1x300 mm ²	Al/St 265/35	NA2XS2Y RM/35 1x630 mm ²	Nexans HTS 10/40
Number of systems	1	1	5	1
Nominal voltage (kV)	110	110	10	10
Continuous current (A)	591	680	2310	2310
Continuous power (MVA)	113	130	40	40
Resistivity (mΩ/km)	95.5	118.3	12.0	0
Reactance (mΩ/km)	188.7	296.3	17.1	11.4
Capacitance (nF/km)	149.1	8.0	3635.0	2880.6
Conductance (nS/km)	46.8	40.0	4568.0	1086.0

Table 1: Electrical line parameters for the urban area power system

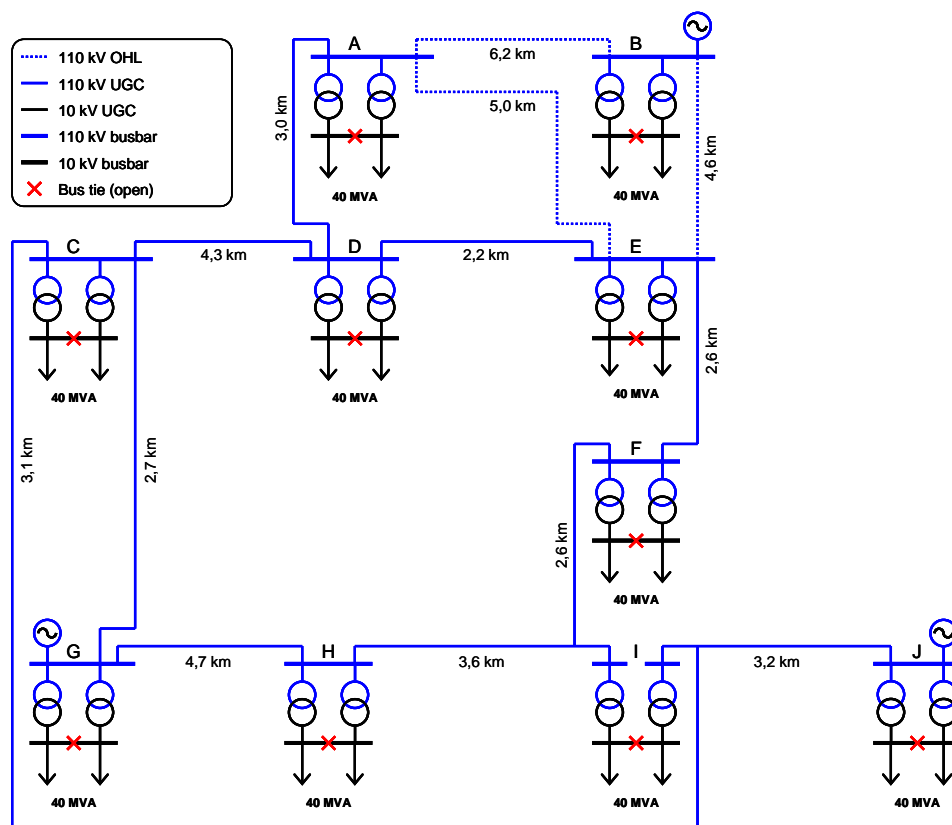

Fig. 1: Urban area grid concept with conventional 110 kV power cables

The intention of this measure is to simplify the grid in reducing the amount of 110 kV cable systems and the number of transformers. In the simplified system two substation types can be found, switching substations

without any transformers as well as transformer substations.

In general, there are two different options to connect



substations with medium voltage HTS cable systems. The first option is connecting a switching substation with two parallel 10 kV HTS cable systems, both with a capacity of 40 MVA, to a transformer substation with three 40 MVA transformers. The second option is connecting a switching substation with two 40 MVA, 10 kV HTS cable systems to two different substations, each with two 40 MVA transformers. The transformer substations are connected with conventional 110 kV cable systems in such a way, that the system with respect to the 110 kV cables is complying with the n-1 criterion. The resulting urban area grid concept with 10 kV HTS cable systems is presented in figure 2, and the electrical parameters are listed in table 1. All transformer substations comply with the n-1 criterion with respect to transformer capacity and also all switching substations comply with the n-1 criterion with respect to the 10 kV connections.

In comparison to the grid concept with conventional 110 kV cables, overall 12.1 km of 110 kV cable system, five 40 MVA transformers as well as the associated 110 kV and 10 kV switchgear are not needed anymore. Additionally, 23.4 km of 10 kV HTS cable system, the associated switchgear for the eight cable connections, and three 10 kV bus ties are required.

Conventional 10 kV cable systems could be an alternative to 10 kV HTS cable systems. In order to reach the transmission capacity of 40 MVA at least five parallel systems of the RWE standard 10 kV aluminum cable with 630 mm² cross section are required. The grid concept for this alternative is the same as with 10 kV HTS cables. The electrical parameters for the conventional 10 kV cable systems can also be found in table 1.

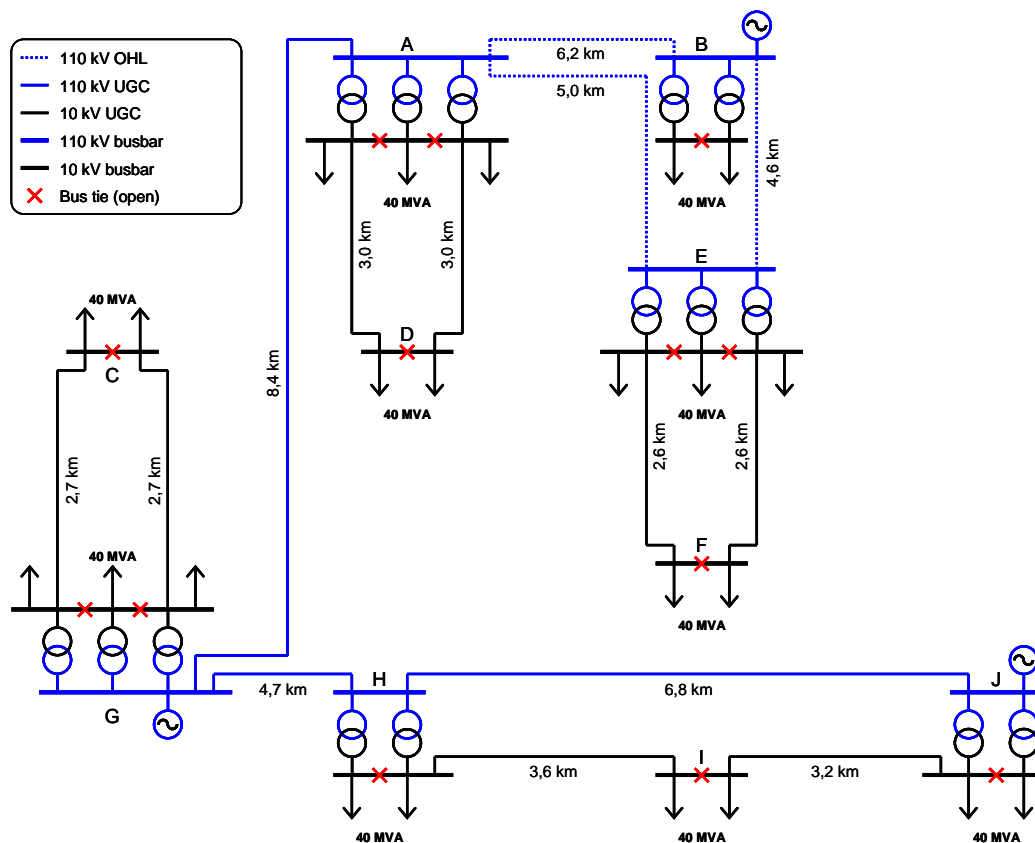

Fig. 2: Urban area grid concept with 10 kV cables

HTS CABLE SYSTEM DESIGN

In figure 3 a suitable superconductor cable design for medium voltage applications is presented. The basis of

the cable core is a hollow former, typically a corrugated tube, which is used as a cooling channel for liquid nitrogen (LN₂). Around the former all three phases and a common screen are concentrically arranged, each of them separated by a lapped dielectric of PPLP (polypropylene



laminated paper). The three phase layers consist of stranded wires containing HTS material, and the common screen is made of stranded copper wires. The cable core is placed into a cryostat, which is composed of two corrugated tubes in concentric arrangement with vacuum insulation in between. Another cooling channel for liquid nitrogen is provided between the cable core and the cryostat.

For medium voltage applications, the concentric arrangement of all three phases allows a very compact cable design. Further, compared to other superconductor cable designs, the amount of superconductor material is significantly reduced. Another major benefit is the integrated return channel for the cooling medium.

Fig. 3: Concentric HTS cable design

During normal operation of the cable system, the currents in the three concentric phases are balanced, exhibiting the same absolute value at a 120° phase shift, and no current flows in the screen. Therefore, no magnetic stray field appears outside the HTS cable system. Additionally, due to active cooling with liquid nitrogen inside the thermal insulating cable cryostat, the system is thermally independent from the environment. This unique thermal behaviour and its very good electromagnetic compatibility leads to a simplified siting as well as easier installation of the HTS cable system.

A possible termination design for the concentric HTS cable system is shown in figure 4. The termination provides the electrical connection of the cable system to the grid as well as the connection to a cooling system. Subcooled liquid nitrogen is circulated through the cable system, keeping the cable core at its operating temperature of maximal 77 K (about -196°C).

Fig. 4: Termination for concentric HTS cables

COMPARISON OF CABLE SYSTEMS

Besides saving space due to reduction of inner city substations with huge transformers, the compact HTS cable design allows a minimized right of way (ROW) for cable installation. The drawing in figure 5 illustrates the required right of way and installation space for three alternative cable systems with the transmission power according to table 1: A conventional 110 kV cable system (left), five conventional 10 kV cable systems (middle) and a 10 kV superconductor cable system with concentric design (right). Furthermore, since superconductor cable systems are thermally independent it is possible to install them in areas sensitive to heat generation.

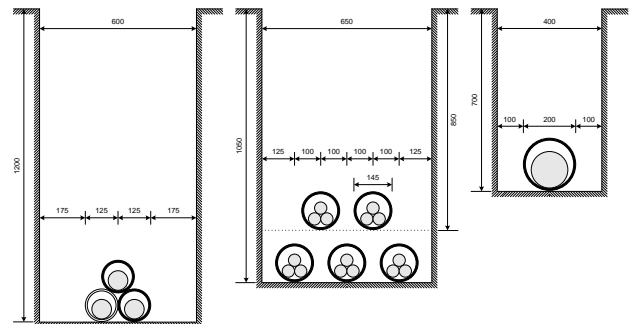

Fig. 5: ROW and installation space comparison

CONCLUSION

The deployment of superconductor cable systems offers attractive alternatives to conventional power cables. Replacing conventional HV cable systems by medium voltage HTS cable systems with high power rating enables the reduction of inner city transformer substations considerably.

Concentric HTS cable systems for MV applications are very compact, exhibit a very good electromagnetic compatibility, and are thermally independent from the environment. For concentric HTS cable systems the required right of way is much smaller and the installation is easier compared to conventional cable systems.

Altogether, the deployment of concentric medium voltage HTS cable systems enables new and quite attractive grid concepts for urban area power supply.

Acknowledgments

The authors would like to thank all the other authors of the original study: Peter Anders, Joachim Bock, Wilfried Goldacker, Francesco Grilli, Achim Hobl, Lutz Hofmann, Martin Kleimaier, Astrid Petermann, Christian Prause, Klaus Schippl, Frank Schmidt, Bernhard Slomka, Rainer Soika and Thomas Theisen.

REFERENCES

- [1] CIGRE Technical Brochure 418, "Status of Development and Field Test Experience with High-Temperature Superconducting Power Equipment", June 2010.
- [2] J.F. Maguire et al., "Development and Demonstration of a HTS Power Cable to Operate in the Long Island Power Authority Transmission Grid", IEEE Transactions on Applied Superconductivity, volume 17, issue 2, part 2, 2034-2037, 2007.
- [3] J.A. Demko et al., "Triaxial HTS Cable for the AEP Bixby Project", IEEE Transactions on Applied Superconductivity, volume 17, issue 2, part 2, 2047-2050, 2007.
- [4] M. Noe et al., "Supraleitende Mittelspannungskabel



zur Stromversorgung in Städten", confidential internal report for RWE, March 2011.

GLOSSARY

HTS: high temperature superconductivity

HV: high voltage

LN₂: liquid nitrogen

MV: medium voltage

OHL: overhead line

PPLP: polypropylene laminated paper

ROW: right of way

UGC: underground cable